

Features

- 8 Bit Microcomputer with 8051 architecture
- Fully static design
- 256B internal RAM
- Low Standby Current At Full Supply Voltage
- 0-33 MHz Operation (12 clock mode)
- 4 8-Bit Bidirectional Ports
- Boolean Processor
- 44 pin PLCC Package
- Built In Power Management
- Three 16 bit timer/counters
- Full Duplex Serial Channel With Hardware Address Decode
- Seven Source, Four Level Interrupt Capability
- Programmable Counter Array
- Watchdog Timer For Greater System Reliability
- Dual Data Pointers
 - PLCC
 - PDIP
 - QFP
- Replaces comparable devices from
 - Intel
 - NXP
 - Atmel

General Description

The TK80C51FA is based on the 8051-microcontroller architecture. ROMless, and with 256x8 of internal RAM, these parts are a pin-for-pin replacement for existing 8031BH, 8032-1, 80C32X2, and 80C51FA type microcontroller from Intel, NXP, Atmel and others.

The TK80C51FA contains four 8-bit bidirectional parallel ports, two external interrupt sources, three timer/counters, a serial port with a hardware interrupt capability and a frame error detect flag, power management, and a programmable counter array (PCA). These peripherals are supported by a multiple source, four level interrupt capability. The core processor contains 256 bytes of scratchpad RAM.

Figure 1 shows the basic TK80C51FA configuration.

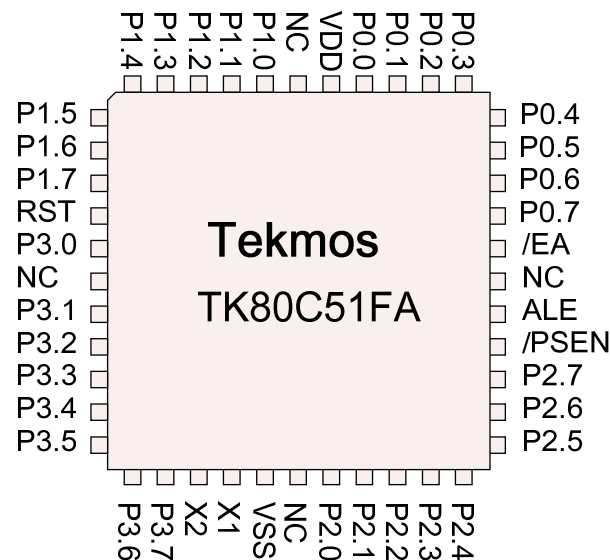

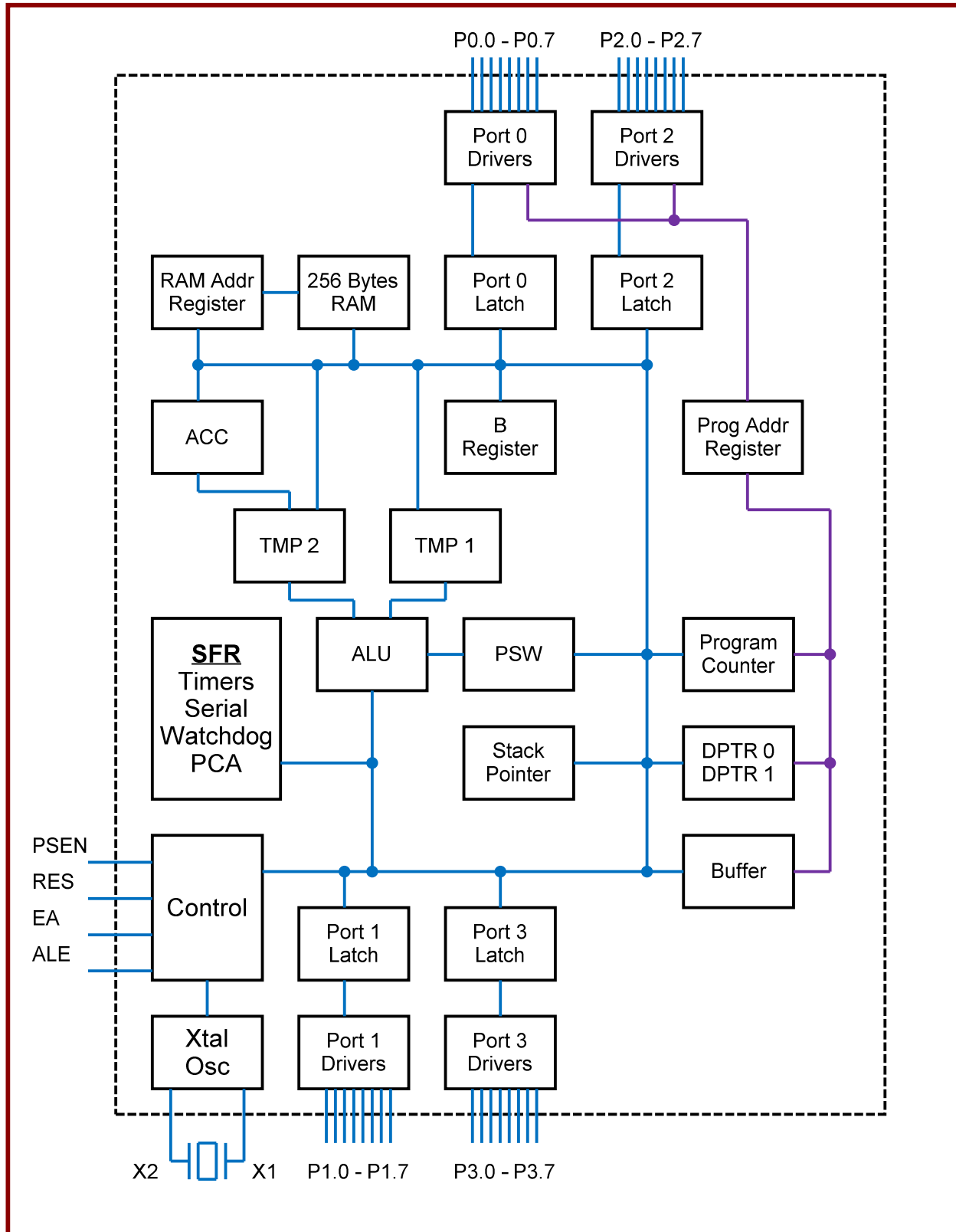

TK80C51FA Block Diagram - Figure 1

Pinout Description

PLCC	PDIP	QFP	Name	Description
1		39	NC	
2	1	40	P1.0 + T2	Port 1, Bit 0 + Timer 2
3	2	41	P1.1 + T2EX	Port 1, Bit 1 + Timer 2 Exchange
4	3	42	P1.2 + ECI	Port 1, Bit 2 + PCA External Clock Input
5	4	43	P1.3 + CEX0	Port 1, Bit 3 + PCA Capture / Compare External I/O for PCA 0
6	5	44	P1.4 + CEX1	Port 1, Bit 4 + PCA Capture / Compare External I/O for PCA 1
7	6	1	P1.5 + CEX2	Port 1, Bit 5 + PCA Capture / Compare External I/O for PCA 2
8	7	2	P1.6 + CEX3	Port 1, Bit 5 + PCA Capture / Compare External I/O for PCA 3
9	8	3	P1.7 + CEX4	Port 1, Bit 5 + PCA Capture / Compare External I/O for PCA 4
10	9	4	RST	Reset
11	10	5	P3.0 + RxD	Port 3, Bit 0 + Serial Port Receive Data
12		6	NC	
13	11	7	P3.1 + TxD	Port 3, Bit 1 + Serial Port Transmit Data
14	12	8	P3.2 + /INT0	Port 3, Bit 2 + External Interrupt 0
15	13	9	P3.3 + /INT1	Port 3, Bit 3 + External Interrupt 1
16	14	10	P3.4 + T0	Port 3, Bit 4 + Timer 0
17	15	11	P3.5 + T1	Port 3, Bit 5 + Timer 1
18	16	12	P3.6 + /WR	Port 3, Bit 6 + Data Write
19	17	13	P3.7 + /RD	Port 3, Bit 7 + Data Read
20	18	14	XTAL2	Clock / Crystal Oscillator Output
21	19	15	XTAL1	Clock / Crystal Oscillator Input
22	20	16	VSS	Ground
23		17	NC	
24	21	18	P2.0 + A8	Port 2, Bit 8 + Address Bus Bit 8
25	22	19	P2.1 + A9	Port 2, Bit 9 + Address Bus Bit 9
26	23	20	P2.2 + A10	Port 2, Bit 10 + Address Bus Bit 10
27	24	21	P2.3 + A11	Port 2, Bit 11 + Address Bus Bit 11
28	25	22	P2.4 + A12	Port 2, Bit 12 + Address Bus Bit 12
29	26	23	P2.5 + A13	Port 2, Bit 13 + Address Bus Bit 13
30	27	24	P2.6 + A14	Port 2, Bit 14 + Address Bus Bit 14
31	28	25	P2.7 + A15	Port 2, Bit 15 + Address Bus Bit 15
32	29	26	/PSEN	Program Store Enable
33	30	27	ALE	Address Latch Enable
34		28	NC	
35	31	29	/EA	External Address
36	32	30	P0.7 + AD7	Port 0, Bit 7 + Address / Data Bus Bit 7
37	33	31	P0.6 + AD6	Port 0, Bit 6 + Address / Data Bus Bit 6
38	34	32	P0.5 + AD5	Port 0, Bit 5 + Address / Data Bus Bit 5
39	35	33	P0.4 + AD4	Port 0, Bit 4 + Address / Data Bus Bit 4
40	36	34	P0.3 + AD3	Port 0, Bit 3 + Address / Data Bus Bit 3
41	37	35	P0.2 + AD2	Port 0, Bit 2 + Address / Data Bus Bit 2
42	38	36	P0.1 + AD1	Port 0, Bit 1 + Address / Data Bus Bit 1
43	39	37	P0.0 + AD0	Port 0, Bit 0 + Address / Data Bus Bit 0
44	40	38	VDD	Positive Supply

Pin Descriptions

Port 0 P00 – P07

With **EA** low, these pins are multiplexed low-byte of the Address or Data Bus when accessing the external program and data memory. Since EA is always low for the TK80C51FA, Port 0 is effectively unusable.

Port 1 P10 – P17

The pins are an 8-bit bi-directional I/O Port with internal pull-ups on all pins.

These pins are multiplexed with internal peripherals. The port data must be a “1” for the alternate function to work correctly.

Name	Port	Alternate Function
T2	P1.0	Timer/Counter 2 External Count Input / Programmable Clock Output
T2EX	P1.1	Timer Counter 2 Reload, Capture, Direction Control
ECI	P1.2	External Clock Input to PCA
CEX0	P1.3	Capture/Compare External IO for PCA module 0
CEX1	P1.4	Capture/Compare External IO for PCA module 1
CEX2	P1.5	Capture/Compare External IO for PCA module 2
CEX3	P1.6	Capture/Compare External IO for PCA module 3
CEX4	P1.7	Capture/Compare External IO for PCA module 4

Port 2 P20 – P27

With **EA** low, these pins are the high-byte of the Address Bus when accessing the external program and data memory. Since EA is always low for the TK80C51FA, Port 2 is effectively unusable, except when it provides the upper address bits for the MOVX instructions.

Port 3 P30 – P37

The pins are an 8-bit bi-directional I/O Port with internal pull-ups on all pins.

Like Port 1, these pins are multiplexed with internal peripherals. The port data must be a “1” for the alternate function to work correctly.

Name	Port	Alternate Function
RXD	P3.0	Serial Input Port
TXD	P3.1	Serial Output Port
INT0	P3.2	External Interrupt
INT1	P3.3	External Interrupt
T0	P1.4	Timer 0 External Input
T1	P1.5	Timer 1 External Input
WR	P1.6	External Memory Write Strobe
RD	P1.7	External Memory Read Strobe

XTAL1, XTAL2

The TK80C51FA has a crystal oscillator connected to the XTAL1 and XTAL2 pins.

An external clock may be used by connecting it directly to the XTAL1 pin. When an external clock is used, the XTAT2 pin should be left unconnected.

EA External Addressing

The EA pin selects whether the 80C51FA executes out of internal or external memory. Since there is no internal memory in this part, the EA pin must be kept low for correct operation.

The state of the EA pin is latched on the falling edge of reset, and has no further effect on the processor.

Reset

The external RESET signal is sampled at S5P2. It must be held high for at least two machine cycles while the oscillator is running to take effect.

A Schmitt trigger should be used in the reset line when an external RC network is used for reset. The reset logic also has a special glitch removal circuit that ignores most glitches on the reset line.

During reset, the ports are initialized to FFH, the stack pointer to 07H, PCON with the exception of bit 4 to 00H, and all of the other SFR registers except SBUF to 00H. SBUF is not reset.

ALE / PSEN

Address Latch Enable, Program Store Enable.

ALE is used to separate the address from the data on the multiplexed address / data bus. The falling edge of ALE is used to latch the lower 8 bits of the address for use by external memory.

PSEN serves as a chip select for the 64K program memory. The RD and WR signals serve a similar function for the data memory

Also during reset, ALE and /PSEN become inputs that are held high with an internal pull-up. These two pins serve to enable various alternate modes.

ALE/PSEN	Function: (When RESET is removed)
01	Emulation Mode
11	Normal Mode

Emulation Mode

The TK80C51FA will remain in reset if reset is removed from the part while ALE is held low and /PSEN is held high. This mode is used to support the use of in-circuit emulators, since all of the TK80C51FA output pins are in a high impedance state during reset.

Architecture

The TK80C51FA consists of a core controller surrounded by four general purpose I/O ports, up to 256 bytes of scratchpad RAM, three timer counters, a serial port, a programmable counter array, a watchdog timer, an enhanced interrupt controller, and various control registers. The processor supports 111 different opcodes, and references both a 64Kb program address space and a 64Kb data storage space.

One of the distinguishing features of the architecture is the Special Function Register (SFR) address space, into which all of the registers, peripherals, and scratchpad RAM are mapped. Many of the instructions operate on an SFR address rather than a specific register. This greatly increases the power of the instruction set.

Address Space

Program Storage Space

The TK80C51FA processor operates out of three separate address spaces. The first of these is the program space. This read-only address space consists of 64K bytes and is used to store the program code. This address space is in external memory. The program space is accessed by both opcode fetches and the MOVC instructions.

Data Space

The second address space is referred to as the data space or extended memory (XRAM) and consists of 64K bytes that can be both read and write memory.

While the data space is separate from the program space, these spaces can be combined in hardware by AND-ing the /PSEN and /RD signals to produce a composite read signal. This will allow the processor to execute code out of RAM. The data space is accessed by the MOVX instructions.

SFR Space

The third address space is referred to as the Special Function Register (SFR) space and consists of 384 bytes located internal to the TK80C51FA. These 384 bytes are mapped into 256 address locations.

The lower 128 bytes of the SFR space consist of scratchpad RAM. While any of these addresses may be used by the programmer, a number of them have special uses. The lower 32 bytes are organized into four 8-byte banks. The bank select bits in the PSW register select one of these banks to be used as an operand by the instruction set. Registers 0 to 7 in the bank are referenced by the register direct opcodes. Registers 0 and 1 may also contain an address that is referenced by the register indirect opcodes.

Registers 20H to 2FH are bit addressable by the Boolean instructions. Register 20H, bit 0 has the Boolean address 00H. Register 2FH, bit 7 has the Boolean address 7FH.

The high level Boolean addresses (80H - FFH) are mapped into the upper 128 bytes of the SFR address space. The upper 5 bits of the Boolean address are combined with three lower bits of 0 to specify a register address. The lower three bits of the Boolean address specify a bit within the designated register.

The upper 128 bytes of the SFR address space contain both 128 bytes of general purpose scratchpad RAM and the SFR registers themselves. They are separated by the addressing means used to access them. Direct addressing accesses the SFR registers. Register indirect addressing will access the scratchpad RAM. Stack pointer operations are considered register indirect addressing. The SFR address space is accessed by all instructions except the MOVC and MOVX instructions.

SFR Registers Bit Maps

Name	Description	SFR Addr.	Reset Value	Bit Functions								
				D7	D6	D5	D4	D3	D2	D1	D0	
ACC	Accumulator	E0h										
AUXR1	Aux. Register 1	A2h	00h	x	x	x	x	GF2	0	x		DPS
B	B Register	F0h										
CCAP0H	PCA Module 0 Capture High	FAh										
CCAP1H	PCA Module 1 Capture High	FBh										
CCAP2H	PCA Module 2 Capture High	FC h										
CCAP3H	PCA Module 3 Capture High	FDh										
CCAP4H	PCA Module 4 Capture High	FEh										
CCAP0L	PCA Module 0 Capture Low	EAh										
CCAP1L	PCA Module 1 Capture Low	EBh										
CCAP2L	PCA Module 2 Capture Low	ECh										
CCAP3L	PCA Module 3 Capture Low	EDh										
CCAP4L	PCA Module 4 Capture Low	EEh										
CCAPM0	PCA Module 0 Mode	DAh	00h	x	ECMO0	CAPP0	CAPN0	MAT_0	TOG_0	PWM_0		ECCF0
CCAPM1	PCA Module 1 Mode	DBh	00h	x	ECMO1	CAPP1	CAPN1	MAT_1	TOG_1	PWM_1		ECCF1
CCAPM2	PCA Module 2 Mode	DCh	00h	x	ECMO0	CAPP2	CAPN2	MAT_2	TOG_2	PWM_2		ECCF2
CCAPM3	PCA Module 3 Mode	DDh	00h	x	ECMO3	CAPP3	CAPN3	MAT_3	TOG_3	PWM_3		ECCF3
CCAPM4	PCA Module 4 Mode	CDE	00h	x	ECMO4	CAPP4	CAPN4	MAT_4	TOG_4	PWM_4		ECCF4
CCON	PCA Counter Control	D8h	00h	CF	CR	x	CCF4	CCF3	CCF2	CCF1		CCF0
CH	PCA Counter High	F9h										
CKCON	Clock Control	8Fh	00h	x	x	x	x	x	x	x		X2
CL	PCA Counter Low	E9h										
CMOD	PCA Counter Mode	D9h	00h	CIDL	WDTE	x	x	x	CPS1	CPS0		ECF
DPH	Data Pointer High	83h										
DPL	Data Pointer Low	82h										
IE	Interrupt Enable	A8h		EA	EC	ET2	ES	ET1	EX1	ET0		EX0
IP	Interrupt Priority	B8h		x	PPC	PT2	PS	PT1	PX1	PT0		PX0
IPH	Interrupt Priority High	B7h		x	PPCH	PT2H	PSH	PT1H	PX1H	PT0H		PX0H
P0	Parallel Port 0	80h		P0.7	P0.6	P0.5	P0.4	P0.3	P0.2	P0.1		P0.0
P1	Parallel Port 1	90h		P1.7	P1.6	P1.5	P1.4	P1.3	P1.2	P1.1		P1.0
P2	Parallel Port 2	A0h		P2.7	P2.6	P2.5	P2.4	P2.3	P2.2	P2.1		P2.0
P3	Parallel Port 3	B0h		P3.7	P3.6	P3.5	P3.4	P3.3	P3.2	P3.1		P3.0
PCON	Power Control	87h		SMOD1	SMOD0	X	POF	GF1	GF0	PD		IDL
PSW	Processor Status Word	D0h		CY	AC	F0	RS1	RS0	OV	F1		P

Name	Description	SFR Addr.	Reset Value	Bit Functions								
				D7	D6	D5	D4	D3	D2	D1	D0	
RCAP2H	Timer 2 Capture High	CBh										
RCAP2L	Timer 2 Capture Low	CAh										
SCON	Serial Control	98h	00h	SM0/FE	SM1	SM2	REN	TB8	TB8	TI	RI	
SBUF	Serial Data Buffer	99h	XXh									
SADDR	Serial Address	A9h										
SADEN	Serial Address Enable	B9h										
SP	Stack Pointer	81h										
TCON	Timer 0 / 1 Control	88h	00h	TF1	TR1	TF0	TR0	IE1	IT1	IE0	IT0	
T2CON	Timer 2 Control	C8h	00h	TF2	EXF2	RCK	TCK	EXEN2	TR2	C/T2	CP/RL2	
T2MOD	Timer 2 Mode Control	C9h	x0h	x	x	x				T2OE	DCEN	
TH0	Timer 0 High	8Ch										
TH1	Timer 1 High	8Dh										
TH2	Timer 2 High	CDh										
TL0	Timer 0 Low	8Ah										
TL1	Timer 1 Low	8Bh										
TL2	Timer 2 Low	CCh										
TMOD	Timer 0 / 1 Mode	89h	00h	GATE	C/T	M1	M0	GATE	C/T	M1	M0	
WDTRST	Watchdog Timer Reset	A6h	00h									

SFR Address Space

	0 / 8	1 / 9	2 / A	3 / B	4 / C	5 / D	6 / E	7 / F	
F8h		CH	CCAP0H	CCAP1H	CCAP2H	CCAP3H	CCAP4H		FFh
F0h	B								F7h
E8h		CL	CCAP0L	CCAP1L	CCAP2L	CCAP3L	CCAP4L		EFh
E0h	ACC								E7h
D8h	CCON	CMOD	CCAPM0	CCAPM1	CCAPM2	CCAPM3	CCAPM4		DFh
D0h	PSW								D7h
C8h	T2CON	T2MOD	RCAP2L	RCAP2H	TL2	TH2			CFh
C0h									C7h
B8h	IP	SADEN							BFh
B0h	P3							IPH	B7h
A8h	IE	SADDR							AFh
A0h	P2		AUXR1				WDTRST		A7h
98h	SCON	SBUF							9Fh
90h	P1								97h
88h	TCON	TMOD	TL0	TL1	TH0	TH1		CKCON	8Fh
80h	P0	SP	DPL	DPH				PCON	87h
	0 / 8	1 / 9	2 / A	3 / B	4 / C	5 / D	6 / E	7 / F	

SFR Registers

The architecture of a processor is defined by its registers. In addition to the 256 general purpose scratchpad registers, the TK80C51FA has more than 60 special purpose registers in the SFR address space.

CPU Registers

Accumulator (ACC or A)

The accumulator provides the implied operand for many of the opcodes. The accumulator has additional hardware associated with it to detect the zero condition, even parity, and to allow it to be shifted when multiply or divide instructions are being executed.

Processor Status Word (PSW)

The PSW register contains the flags resulting from ALU operations, status bits, and control bits. Here are the bit definitions:

Processor Status Word (PSW)		
Bit	Name	Function
7	CY	Carry Flag
6	AC	Auxiliary Carry. Used in BCD operations.
5	F0	Flag 0. This is a user definable flag.
4	RS1	Register Select 1. Used with RS0 to select the working register bank.
3	RS0	Register Select 0.
2	OV	Overflow Flag
1	F1	Flag 1. This is another user definable flag.
0	P	Parity. This is the even parity of the accumulator contents.

B Register

The B register is used by both the multiply and divide instructions. Prior to the instruction it holds one of the operands, and after the instruction it will hold either the upper 8 bits of the multiply result or the remainder from the divide operation. At other times the B register may be used as a general purpose register.

Stack Pointer (SP)

The stack pointer contains an indirect address that is used to store or recall data associated with the PUSH, POP, CALL, RET, and RETI instructions and with interrupt servicing. The SP register is initialized by reset to a value of 07H. It is incremented prior to storing data, which means that the stack will begin at location 08H.

Data Pointer

The data pointer register is a 16 bit register organized as two 8 bit registers, DPL and DPH. It holds a 16 bit address that is used by the MOVX and MOVC instructions to access the program and data memories.

There is a second identical data pointer register. The DPS bit in the AUXR1 register may be used to select between the two data pointers. The presence of a second data pointer

Auxiliary Register 1 (AUXR1)

The AUXR1 register controls the dual data pointer flag. IT also contains a general purpose flag.

AUXR1 (A2h)		
Bit	Name	Function
7	-	Unused
6	-	Unused
5	-	Unused
4	-	Unused
3	GF2	General purpose flag
2	0	Always 0
1	-	Unused
0	DPS	Data Pointer Select

DPS – Selects between DPTR0 (0) and DPTR1 as the active Data Pointer.

GF2 – General Purpose user defined flag. Note that bit 2 is a zero allowing the DPS bit to be toggled with an INC AUXR1 instruction.

I/O Ports

The TK80C51FA has 4 8-bit bidirectional I/O ports. These ports are mapped into the SFR address space and may be directly operated on by instructions. The port bits are configured as open-drain bidirectional pins. Writing a 1 to the port allows that bit to be configured as an input.

With EA low, Ports 0 and 2 are replaced by the multiplexed address / data bus and are effectively unusable.

Port 0

During external RAM and ROM operations, Port 0 serves as a multiplexed address/data bus. During this time, the pins have push-pull capability. The ALE signal serves as a strobe for external logic to demultiplex the Port 0 address from the data. Port 0 is set to FFH during external operations to avoid conflict with incoming data.

Port 0 is located at address 80H.

Port 1

This port also provides the T2 and T2EX inputs for Timer 2 in the 8052 and 8051FB configurations and the ECI and CEXn inputs for the PCA in the 8051FB.

Port 1		
Pin	Name	Alternate Function
P1.0	T2	Timer 2 clock
P1.1	EXF2	Timer 2 gate
P1.2	ECI	PCA Clock
P1.3	CEX0	PCA 0 I/O
P1.4	CEX1	PCA 1 I/O
P1.5	CEX2	PCA 2 I/O
P1.6	CEX3	PCA 3 I/O
P1.7	CEX4	PCA 4 I/O

Port 1 is located at address 90H.

Port 2

Port 2 provides the upper byte for the address during external ROM and RAM operations.

Port 2 is located at address A0H.

Port 3

Port 3 pins support the serial port, Timer 0, Timer 1, the external interrupt functions, and the read and write strobes for the external data space.

Port 3		
Pin	Name	Alternate Function
P3.0	RXD	Serial Receive Data
P3.1	TXD	Serial Transmit Data
P3.2	/INT0	External Interrupt 0
P3.3	/INT1	External Interrupt 1
P3.4	T0/CEX3	Timer 0 Input
P3.5	T1/CEX4	Timer 1 Input
P3.6	/WR	Data Write Strobe
P3.7	/RD	Data Read Strobe

Port 3 is located at address B0H.

Read-Modify-Write Instructions

Since each port pin is configured as an open-drain, it is possible for the contents of the port latch to differ from the value at the pin. Instructions that read the port reference the value at the pin. An exception to this is a set of instructions that perform a read-modify-write function. These instructions read the contents of the port latch, modify it, and write it back out. The read-modify-write instructions are:

- ANL
- CLR B
- CPL
- DEC
- DJNZ
- INC
- JBC
- MOV B, C
- ORL
- SET B
- XRL

Precharge

Each pin in Port 0 is configured as a bidirectional open-drain when it is used as a port. The pins become push-pull during the multiplexed address/data operation.

The other three ports have an internal pull-up resistor on each pin. In addition, whenever a port makes a 0 to a 1 transition, a precharge occurs for two crystal clock cycles. This precharge improves the rise times of the port pins. The precharge also occurs during the alternate port functions.

Port 2 pins also become push-pull outputs during external memory cycles.

Serial Port

The TK80C51FA contains a full duplex serial port. This port is receive buffered and can be operated in any of 4 different modes. The serial port also has the ability to analyze a received word to determine if it is data or an address, and then selectively generate an interrupt depending on which address has been received.

Mode 0

The serial port acts as a synchronous shift register in Mode 0. Data is shifted into and out of the RXD pin. The shift clock appears on the TXD pin.

A write to the SBUF register begins the transmission. Data is shifted out LSB first. Data bits are shifted out once per machine cycle, which is $F_{osc}/12$.

Setting the bits $REN = 1$ and $RI = 0$ in the SCON register begins a receive cycle.

Mode 1

While in Mode 1, the serial port acts as a UART with 1 start bit, 8 data bits, and 1 stop bit. The baud rate may be different for both the transmit and receive. The baud rate is selected from either the Timer 1 overflow rate or the Timer 2 overflow rate.

The receive stop bit is stored in RB8.

Mode 2

Mode 2 causes the serial port to be a UART with 1 Start Bit, 8 data bits, 1 control bit, and 1 stop bit. The baud rate is either $F_{osc}/32$ or $F_{osc}/64$, depending on the SMOD bit. The control bit may be used for parity, or it can be used in multiprocessor communications. This is described in the address recognition section.

Mode 3

Mode 3 is the same as mode 2, except that the baud rate is derived from either the Timer 1 or the Timer 2 overflows.

Frame Errors

A frame error is defined as a missing stop bit. Should a frame error occur, the FE bit is set. No other action is taken. The reception of a good frame following a bad one will reset the FE bit.

To read the FE bit, the SCON0 bit in PCON (Bit 6) must be set. This replaces the SM0 bit in SCON (Bit 7) with the FE bit.

Transmission

Transmission is initiated by writing a byte to the SBUF register. The transmitter is not buffered, so caution must be exercised to avoid overwriting the transmitter. The software should wait until the TI bit has been set before writing the next byte.

Interrupts

A serial port interrupt request is generated whenever the RI or the TI bits have been set. The serial port hardware sets the TI bit after a transmit is finished, and it sets the RI bit after a word has been received.

It is up to the programmer to determine which source caused the serial port interrupt, and to clear the bits during the interrupt service.

Address Recognition

The serial port has some special hardware to assist in multiprocessor communications. If the SM2 bit is set, and the serial port is operating in either modes 2 or 3, then the receive interrupt may be suppressed depending on the received bit 8 and the data contents.

If RB8 is a 0, then the byte is assumed to be a data byte, and no interrupt is generated.

If RB8 is a 1, then the received byte is considered to be an address. An interrupt will be generated if the address matches the address in the SADDR register, as modified by the SADEN register. The receive address is compared to the SADDR register on a bit by bit basis. The results of this comparison are enabled by the corresponding bit in the SADEN register. A bit match occurs if either the bits are the same and the enable bit is set, or the enable bit is not set. If a bit match occurs for all 8 bits, then a receive interrupt is generated.

The serial port also supports a broadcast address that is formed by the logical OR of the SADDR and SADEN registers, with 0's being defined as don't cares. A receive interrupt will be generated if the address matches the broadcast address.

Serial Port Control Registers

The serial port is controlled by the SCON register and two of the bits in the PCON register.

SCON (98h)		
Bit	Name	Function
7	SM0/FE	Serial Mode Bit 0 or FE Frame Error
6	SM1	Serial Mode Bit 1
5	SM2	Serial Mode Bit 2
4	REN	Receiver Enable
3	TB8	Transmit Bit 8
2	TB8	Receive Bit 8
1	TI	Transmit Interrupt
0	RI	Receive Interrupt

Serial Modes		
SM0 / 1	Mode	Baud Source
0 0	0	Fosc/12
0 1	1	Variable
1 0	2	Fosc/32, Fosc/64
1 1	3	Variable

PCON (87h)		
Bit	Name	Function
7	SMOD	Doubles Timer 1 Baud Rate
6	SMOD0	Enables FE Bit in SCON

Serial Port Data Registers

The following registers are data registers associated with the serial port.

- SBUF Register - SFR Address = 99H
- SADDR Register - SFR Address = A9H
- SADEN Register - SFR Address = B9H

Timer 0 and Timer 1

Timer 0 and Timer 1 are two independent timer/counters, but both are configured by the TMOD register and controlled by the TCON register. These registers allow the programmer to select and control the clock source and to operate either timer in any of 4 different operating modes. Since the TCON register address is 88H, it may be

operated upon on a bit by bit basis with the microcontroller Boolean instructions.

Clock Control

There is considerable flexibility in the control of the clock for either timer. The C/T bit in the TMOD register selects the source of the clock. Setting it to a one selects the external Tn pin as a clock source, while clearing it to a zero selects the internal clock.

After the source has been selected, it is further controlled by the TRn bit of the TCON register. Clearing this bit blocks the clock and prevents operation. Setting the bit enables the clock.

The clock can also be controlled by the GATEN bit in the TMOD register. Setting this bit allows the external interrupt pin to gate the clock. A 1 on the external interrupt pin enables the clock.

The clock controls act as an enable on the clock generator. This prevents spurious clocks from being generated when the controls are switched.

Clock Speed

When operating off the internal clock source, the timers will be incremented once every machine cycle. Since there are twelve external clocks per machine cycle, the maximum count frequency is Fosc/12.

External pins are sampled once per machine cycle. If the external clock source is selected, it will take two machine cycles to create a complete clock waveform, thus making the maximum external clock frequency Fosc/24. While there are no limitations on the external clock duty cycle, care must be taken to insure that the clock signal has been sampled correctly during the S5P2 time. This is easily accomplished by maintaining the external clock in a given state for a minimum of one machine cycle.

Operating Modes

The timer/counters may be operated in one of four modes. The mode is selected by the two mode bits in the TMOD register. Timer 0 and Timer 1 behave identically in the first three modes.

Mode 0

In Mode 0, the timer operates as a 13 bit counter. The THn register serves as the upper 8 bits, and the TLn register provides the lower 5 bits. The upper three bits of the TLn register will increment,

but they have no effect on the counter operation. As the counter rolls over from all ones to all zeros, it will set the TF_n flag in the TCON register.

Mode 1

In Mode 1, the timer operates as a 16 bit counter. As in Mode 0, when the counter rolls over from all ones to all zeros, the TF_n flag is set.

Mode 2

In Mode 2, the TL_n register acts as an 8 bit counter with an automatic reload from the contents of the TH_n register when the counter rolls over. The TF_n flag is set at the reload time.

Mode 3

In Mode 3, Timer 0 functions as two separate 8 bit counters. TL0 is controlled by the Timer 0 control bits. TH0 is controlled by the Timer 1 control bits. When Timer 0 is in Mode 3, Timer 1 may still be operated as a timer or used as a baud rate generator. However, it is not able to set the TF1 bit. Placing Timer 1 in Mode 3 has the same effect as clearing the TR1 bit, which turns Timer 1 off.

Interrupts

The setting of the TF_n bit in the TCON register triggers an interrupt request. The TF_n bit is reset by hardware when the requested interrupt is acknowledged.

The TCON register also controls the external interrupts. These functions are explained in the interrupt section.

Baud Rate Generation

The overflow of Timer 1 is directly connected to the Serial port as a possible baud rate clock source. This is useful when Timer 0 is being operated in Mode 3 and none of the controls for Timer 1 are available.

The Timer Data Registers

Each timer consists of a lower register (TL_n) and an upper register (TH_n). These registers are treated as any other SFR register and may be read from or written to at any time. These registers are unbuffered and represent the current count value. The data registers are mapped into the SFR address space at the following locations:

Register Address

TL0	8AH
TL1	8BH
TH0	8CH
TH1	8DH

The Timer Control Registers

Timer 0 and Timer 1 are controlled by the TMOD and TCON registers. As with the data registers, the control registers may be treated as any other SFR register, and may be read from or written to at any time.

The TMOD register serves as a mode select register. The upper nibble controls Timer 1 and the lower nibble controls Timer 0.

The TCON register controls the enables for each timer, the timer interrupt bits, the edge selects for external interrupts and the external interrupt bits. Interrupt bits generate the interrupt and may be set by software as well as hardware. Here are the bit assignments for the TMOD and TCON registers.

TMOD (89H)		
Bit	Name	Function
7	GATE1	Timer 1 clock gate enable
6	C/T1	Counter/Timer 1 clock source select
5	M11	Mode select bit 1 for Timer 1
4	M10	Mode select bit 0 for Timer 1
3	GATE0	Timer 0 clock gate enable
2	C/T0	Counter/Timer 0 clock source select
1	M01	Mode select bit 1 for Timer 0
0	M00	Mode select bit 0 for Timer 0

TCON (88H)		
Bit	Name	Function
7	TF1	Timer 1 interrupt bit
6	TR1	Timer 1 run enable bit
5	TF0	Timer 0 interrupt bit
4	TR0	Timer 0 run enable bit
3	IE1	Interrupt 1
2	IT1	Interrupt 1 edge select
1	IE0	Interrupt 0
0	IT0	Interrupt 0 edge select

Timer 2

Timer 2 is a sixteen bit up/down counter which is configured by the T2MOD register and controlled by the T2CON register. Timer 2 is equipped with a capture/reload capability. As with the Timer 0 and Timer 1 counters, there exists considerable flexibility in selecting and controlling the clock and in defining the operating mode.

Clock Control

The clock source for Timer 2 may be selected from either the external T2 pin ($C/T2=1$) or the crystal oscillator ($C/T2=0$). The clock is then enabled when TR2 is a one, and disabled when TR2 is a zero.

Clock Speed

The external clock is sampled once each machine cycle. This puts the maximum speed of the internal clock at $F_{osc}/24$. The designer must insure that the external clock signal is valid during the S5P2 sampling time.

During the capture and auto-reload modes, the timer is clocked once per machine cycle, which represents a clock frequency of $F_{osc}/12$. During the baud mode, the timer is clocked once per internal clock, which represents a clock frequency of $F_{osc}/2$.

Operating Modes

Timer 2 has four modes of operation. These are the capture mode, an auto-reload mode with DCEN=0, an auto-reload mode with an up/down count capability, and a baud mode.

Capture Mode

The capture mode is enabled by setting the CP/RL2 bit in the T2CON register to a 1. In the capture mode, Timer 2 serves as a 16 bit up counter. When the counter rolls over from all 1's to all 0's, the TF2 bit is set, which will generate an interrupt request.

If the EXEN2 bit is set, then a negative transition of the T2EX pin will cause the value in the TL2 and TH2 registers to be captured by the RCAP2L and RCAP2H registers. This action also causes the EXF2 bit in T2CON to be set, which will also generate an interrupt.

Auto-reload Mode, Counting Up

The auto-reload mode as an up counter is enabled by clearing the CP/RL2 bit in T2CON and clearing the DCEN bit in T2MOD. In this mode, Timer 2 is a 16 bit up counter. When the counter rolls over from all 1's, a reload is generated that causes the contents of the RCAP2L and RCAP2H registers to be loaded into the TL2 and TH2 registers. The reload action also sets the TF2 bit.

If the EXEN2 bit is set, then a negative transition of the T2EX pin will also cause a reload. This action also sets the EXF2 bit in T2CON.

Auto-reload Mode, Counting Up/Down

Timer 2 will be in an auto-reload mode as an up/down counter if the CP/RL2 bit in T2CON is cleared and the DCEN bit in T2MOD is set. In this mode, Timer 2 is an up/down counter whose direction is controlled by the T2EX PIN. A one on this pin causes the counter to count up.

An overflow while counting up will cause the counter to be reloaded with the contents of the capture registers. The next down count following the case where the contents of Timer 2 equal the capture registers will load an 0FFFFH into Timer 2. In either event a reload will set the TF2 bit. A reload will also toggle the EXF2 bit. However, the EXF2 bit cannot generate an interrupt request while in this mode.

Baud Rate Mode

The baud rate mode is enabled by setting either the RCLK or TCLK bits in the T2CON register. While in the baud rate mode, Timer 2 is a 16 bit counter with auto reload when the count rolls over from all 1's. However, rolling over does not set the TF2 bit.

If the EXEN2 bit is set, then a negative transition of the T2EX pin will set the EXF2 bit in T2CON and cause an interrupt request.

Interrupts

Interrupt requests for Timer 2 are generated from the TF2 bit and the EXF2 bit, depending on the operating mode. Unlike Timers 0 and 1, these bits are not reset by the interrupt and must be cleared by software. The Timer 2 interrupt service routine is located at address 002BH.

Timer 2 Data Registers

There are 4 data registers associated with Timer 2. TL2 and TH2 are the lower and upper bytes of Timer 2. RCAP2L and RCAP2H are the lower and upper capture and reload registers for the timer. The data registers are mapped into the SFR address space at the following locations.

Register	Address
RCAP2L	CAH
RCAP2H	CBH
TL2	CCH
TH2	CDH

The timer clocks are skewed with respect to the processor cycles, so they can be read or written to at any time without problem. However, when Timer 2 is operated in the baud mode and using the divide-by-two clock, the timer contents will be changing at high speed. This will interfere with their being correctly operated upon by read-modify-write instructions.

Timer 2 Control Registers

The T2MOD and T2CON registers control Timer 2. As with the data registers, these registers may be written to and read from at any time without conflict with the timer operation.

T2MOD (C9h)		
Bit	Name	Function
7		Unused
6		Unused
5		Unused
4		Unused
3		Unused
2		Unused
1	T2OE	Timer 2 Output Enable
0	DCEN	Down Count Enable. A 1 enables the Up/Down capability in the auto-reload mode

T2CON (C8h)		
Bit	Name	Function
7	TF2	Timer 2 Flag
6	EXF2	Timer 2 External Flag
5	RCLK	Receive clock enable
4	TCLK	Transmit clock enable
3	EXEN2	External Enable
2	TR2	Timer 2 Run Enable
1	C/T2	Counter/Timer select
0	CP/RL2	Capture/Reload select

Programmable Counter Array (PCA)

The TK80C51FA contains a programmable counter array. This array consists of a 16 bit counter, five compare modules, and control logic. The counter may be programmed to operate off a choice of four different sources. Each compare module may in turn be programmed to operate in one of five different modes. The operating modes may generate interrupts through a dedicated interrupt channel.

Figure PCA-1 shows the general organization of the PCA.

Control Registers

The PCA uses seven control registers. Each of the five modules has its own control register, which are called the CCAPMn registers. There are two additional registers, the CCON and CMOD registers, which control the 16 bit counter and provide overall control and mode functions. Here are the control registers and their bit assignments.

CMOD (C1h)		
Bit	Name	Function
7	CIDL	Counter Idle Control
6	WDTE	Watchdog Timer Enable
5		
4		
3		
2	CPS1	Count Pulse Select 1
1	CPS0	Count Pulse Select 0
0	ECF	Enable Counter Overflow Interrupt

CCON (C0h)		
Bit	Name	Function
7	CF	Ctr. Overflow Flag
6	CR	Counter Run Enable
5		Not Used
4	CCF4	Mod 4 Interrupt Flag
3	CCF3	Mod 3 Interrupt Flag
2	CCF2	Mod 2 Interrupt Flag
1	CCF1	Mod 1 Interrupt Flag
0	CCF0	Mod 0 Interrupt Flag

CCAPMn (C2H-C6H)		
Bit	Name	Function
7		Not used
6	ECOMn	Enable Comparator
5	CAPPn	Capture Positive
4	CAPNn	Capture Negative
3	MATn	Match
2	TOGn	Toggle
1	PWMn	Pulse Width Modulation
0	ECCFn	Enable CCF Interrupt

Data Registers

All of the counters and compare modules are accessible as SFR addresses.

Register	Address	Function
CL	E9H	Lower Counter
CH	F9H	Upper Counter
CCAP0L	EAH	Lower Module 0
CCAP0H	FAH	Upper Counter 0
CCAP1L	EBH	Lower Module 1
CCAP1H	FBH	Upper Counter 1
CCAP2L	ECH	Lower Module 2
CCAP2H	FCH	Upper Counter 2
CCAP3L	EDH	Lower Module 3
CCAP3H	FDH	Upper Counter 3
CCAP4L	EEH	Lower Module 4
CCAP4H	FEH	Upper Counter 4

Sixteen Bit Counter

The PCA is built around a central 16 bit counter. This counter provides the time information to each of the 5 compare modules. The lower 8 bits are in the CL register and the upper 8 bits are in the CH register. These registers may be read and written to at any time. As with any running counter, care should be taken when writing to the CL and CH registers to prevent false decodes.

The clock source may be selected from one of four different sources by the CPS1 and CPS0 bits in the CMOD register. A 00 selects the internal machine cycle clock, which is $F_{osc}/12$. A 01 selects one half of the internal clock, which is $F_{osc}/4$. A 10 selects Timer 0 overflow as the clock. A 11 selects an external clock from the P12 pin. The maximum rate for this clock will be $F_{OSC}/8$. Unlike other SFR pins which are sampled every $F_{osc}/12$, this pin is sampled at a $F_{OSC}/4$ rate.

The clock for the counter is gated by the CR bit in the CCON register. The clock may also be gated by the processor being in the idle mode and the CIDL bit being set.

When the counter overflows, it sets the CF bit in the CCON register. Depending on the status of the ECF bit in the CMOD register, this overflow can trigger an interrupt request.

Figure PCA-2 shows the counter clock and interrupt circuit.

Capture Modules

A capture module consists of a 16 bit compare register, a 16 bit comparator, and a control register. A match out of the comparator sets the CCFn flag, which in turn can be used to generate an interrupt. A match can also be brought out of the chip through one of the CEXn pins.

Capture Mode

Bits 4 or 5 of the CCAPMn register, with bits 1, 2, 3, and 6 = 0 enable a capture mode. In this mode, a rising (Bit 5) or falling (Bit 4) edge on the CEXn pin creates a capture signal. The capture signal transfers the contents of the 16 bit counter into the CCAPnH and CCAPnL registers.

The capture signal will set the CCFn bit in the CCON register. Enabling the ECCFn bit will allow the CCFn bit to trigger an interrupt.

Figure PCA-3 shows the configuration of the capture mode.

Software Timer Mode

A 16 bit software timer with an optional output may be created by clearing bits 1, 4, and 5, and controlling the ECOMn (Bit 6), MATn (Bit 3), TOGn (Bit 2), and ECCFn (Bit 0).

Setting the ECOMn bit enables the 16 bit comparator. When the count equals the value in the CCAPn registers, an equal signal is generated. Setting the MATn bit will allow this signal to set the CCFn bit in the CCON register. And setting the ECCFn bit will allow the CCFn bit to generate an interrupt.

The TOGn bit enables the equal signal to clock a toggle flip-flop, whose output is visible on the CEXn pin.

Writing to the CCAPnL register clears the ECOMn bit, thus disabling the comparator. Writing to the CCAPnH register sets the ECOMn bit, re-enabling the comparator. This is done to allow the programmer to make changes to the CCAPn register without causing output glitches.

Figure PCA-4 shows the configuration of the software timer mode.

Pulse Width Modulation (PWM) Mode

Clearing bits 0, 2, 3, 4, and 5 of the CCAPMn register and setting the PWMn and ECOMn bits enable the PWM mode. In this mode, the CEXn pin is a 1 when the CL count is greater than or equal to the value in the CCAPn registers, and CEXn is zero when the CL count is less than the CCAPnL value. When the CL register rolls over, the value in the CCAPnH register is transferred into the CCAPnL register. This allows for the programmer to change the value for the PWM signal without causing a glitch.

Programming the CCAPnH register with numbers ranging from 00H to FFH causes the output duty cycle to range from 100 percent to 0.4 percent.

Figure PCA-5 shows the configuration of the PWM mode.

Watchdog Timer Mode

Setting bits 1, 4, and 5 to zero and bit 3 to a one in the CCON4 register and setting the WDTE bit in the CMOD register enables the watchdog timer mode in module 4. The timer is controlled through the ECOM4 bit. When an equal between the counter bus and the contents of the CCAP4 register is detected, the watchdog timer resets the processor. To prevent the watchdog timer from resetting the processor, it is the responsibility of the programmer to insure that the equal is never generated. This is easily done by changing the values in the CCAP4 registers or by changing the values in the CH/CL registers. Changing the WDTE bit is not recommended, since the processor could conceivably fail while the timer was disabled.

Figure PCA-6 shows the configuration of the watchdog timer mode.

PCA Interrupts

The PCA has six interrupt sources. Each module has one, and the counter overflow is the sixth. These interrupt requests are OR'ed together to create the PCA interrupt request. The interrupt routine must determine the source of the interrupt and clear it before returning from the interrupt.

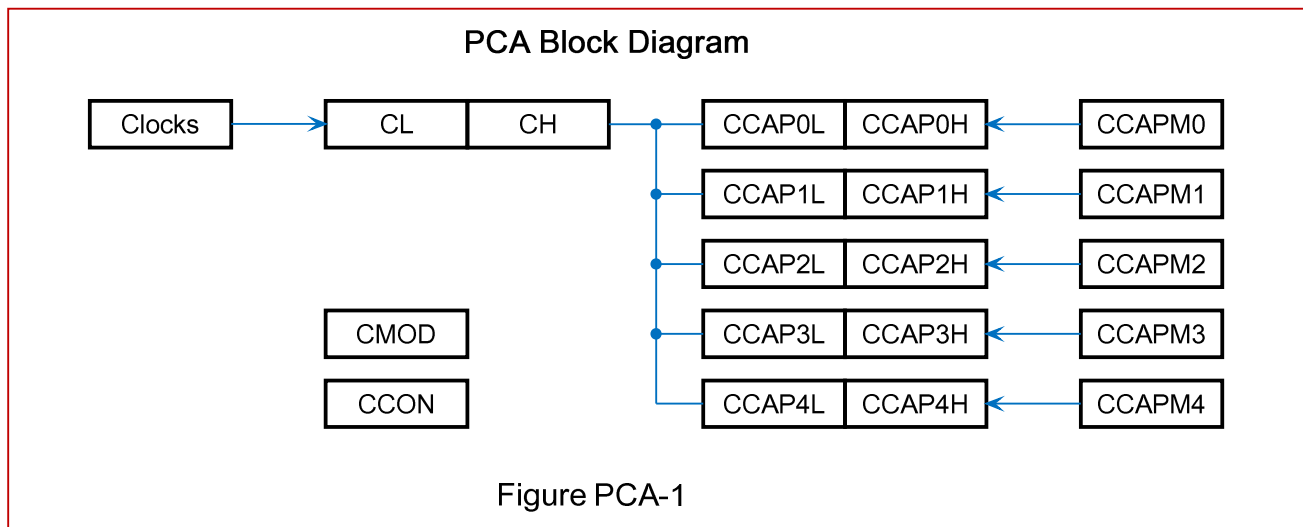

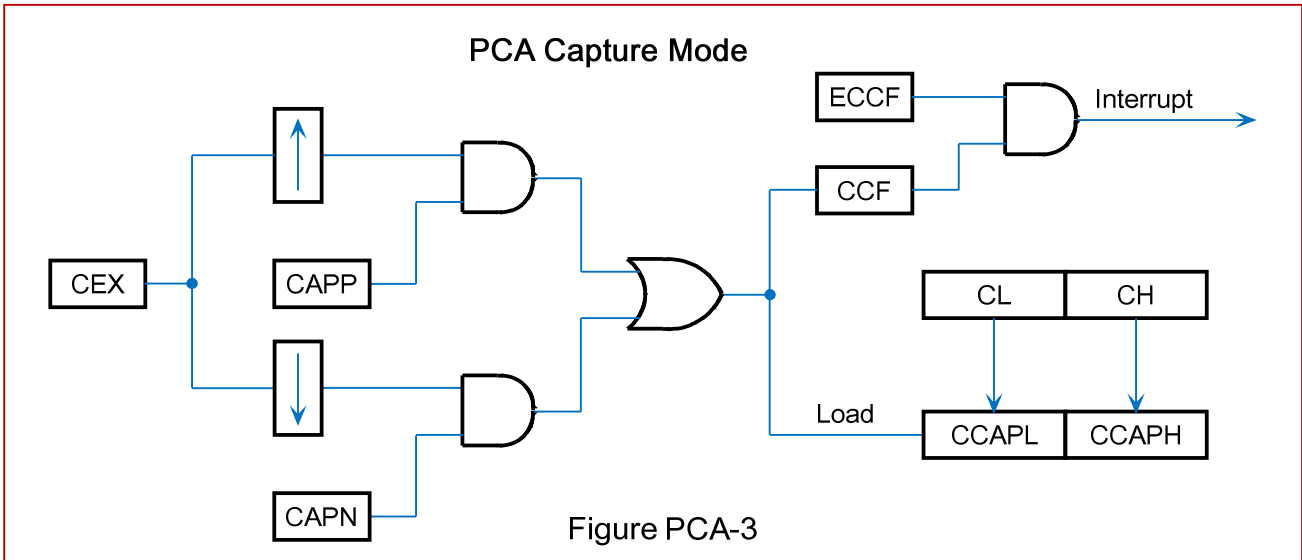
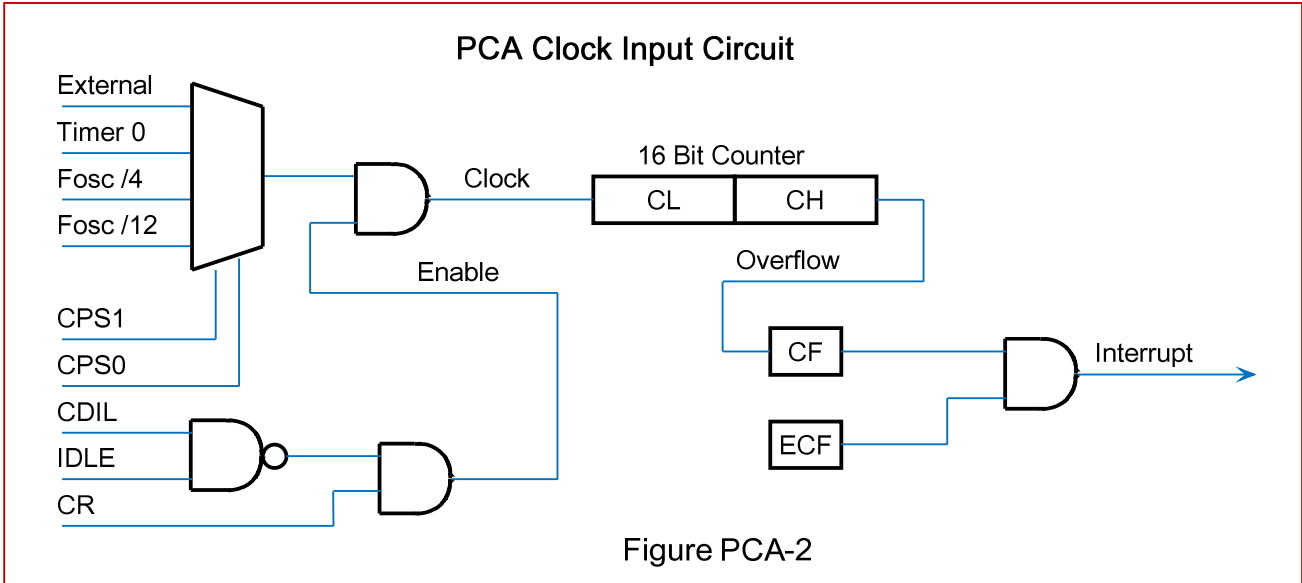

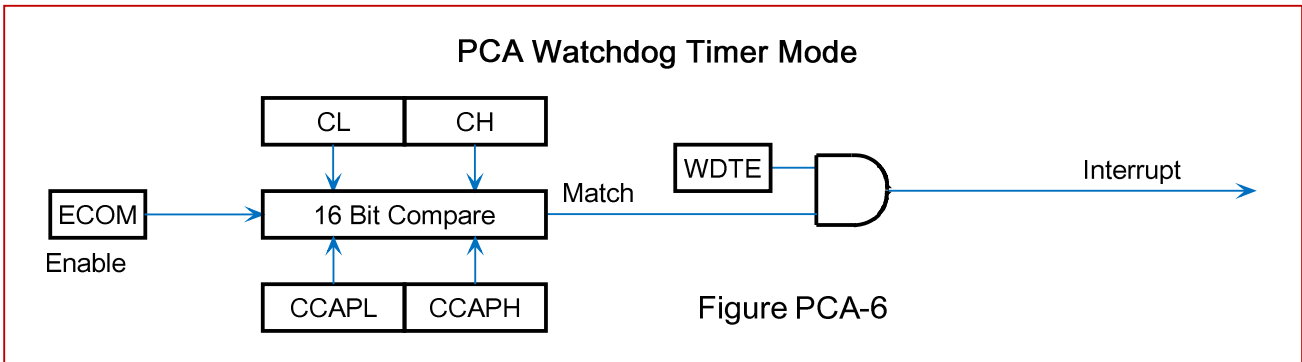
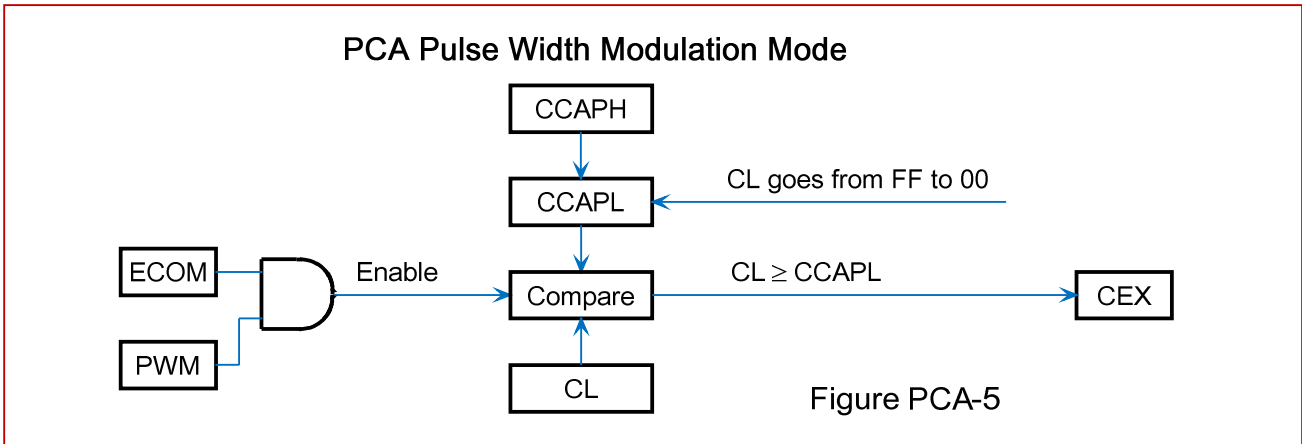
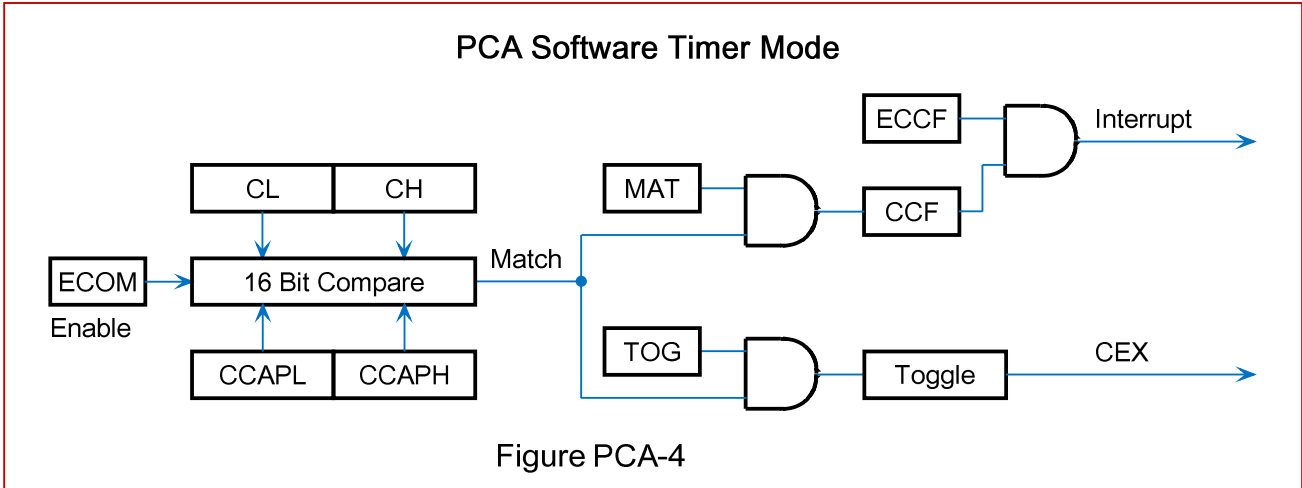

Interrupt Controller

The TK80C51FA has seven interrupt channels. These channels may be individually or collectively enabled, and each may be assigned one of four priority levels. The interrupt channels are dedicated to specific functions within the TK80C51FA and are controlled by bits in the control registers.

An interrupt may be generated by software by setting the appropriate control bits.

External Interrupts

The TK80C51FA has two external interrupts, which are called /INT0 and /INT1. The IT0 and IT1 bits in the TCON register determine if these interrupts are level triggered (ITn=0) or falling edge triggered (ITn=1). The interrupt bit will be reset by the interrupt hardware if it was an edge triggered interrupt. It is the programmer's responsibility to insure that the external event that generates a level triggered interrupt is satisfied and that the input is removed before the end of the interrupt service routine.

Timer 0, 1 Interrupts

Overflows in Timer 0 and 1 set the TFn bits in the TCON register. They in turn generate the interrupt. As with the external interrupts, the interrupt hardware will reset the interrupt bit during the interrupt routine.

Serial Port Interrupts

A serial port interrupt will be generated if either the RI or the TI bits in the SCON register have been set. It is the programmer's responsibility to determine whether the transmitter or the receiver generated the interrupt. Also, the interrupt bits must be cleared by software.

Timer 2 Interrupts

Both the EXF2 and the TF2 bit in the T2CON register will generate a Timer 2 interrupt. As with the serial port, the programmer has the responsibility to determine who caused the interrupt and to reset the interrupt bits.

The EXF2 bit will not generate an interrupt if the timer is in the auto-reload mode and DCEN is 1.

PCA Interrupts

Either the CF counter overflow bit or any of the five CCFn bits can generate a PCA interrupt request

Interrupt Enables

Each interrupt channel may be individually enabled by setting the appropriate bit in the interrupt enable (IE) register. The EA (Enable All) bit must also be set to enable an interrupt.

IE (A8h)		
Bit	Name	Function
7	EA	Enable All
6	EC	Enable PCA
5	ET2	Enable Timer 2I
4	ES	Enable Serial
3	ET1	Enable Timer 1
2	EX1	Enable External 1
1	ET0	Enable Timer 0
0	EX0	Enable External 0

Interrupt Priorities

Each interrupt channel is assigned a bit in the interrupt priority (IP) register. Setting the bit increases the interrupt priority level. Within the priority level, there exists a priority sequence. The priority level takes precedence over the priority sequence. These are listed along with the vector locations below.

IP (B8h)		
Bit	Name	Function
7	x	
6	PPC	PCA
5	PT2	Timer 2
4	PS0	Serial
3	PT1	Timer 1
2	PX1	External 1
1	PT0	Timer 0
0	PX0	External 0

IPH (B7h)		
Bit	Name	Function
7	x	
6	PPCH	PCA
5	PT2H	Timer 2
4	PS0H	Serial
3	PT1H	Timer 1
2	PX1H	External 1
1	PT0H	Timer 0
0	PX0H	External 0

Interrupt Vector Locations		
Address	Priority	Source
0003h	1	IE0
000Bh	2	IT0
0013h	3	IE1
001Bh	4	TF1
0023h	6	RI + TI
002Bh	7	TF2 + EXF2
0033h	5	CF + CCFn

Interrupt Response

An interrupt begins with the setting of the appropriate bit in a control register. The interrupt hardware compares the bit with the enables and priorities to determine if an interrupt request is warranted and which interrupt should be requested. This logic provides either a request for a priority 1 or a priority 0 interrupt. This logic also prepares a vector address for the interrupt service routine.

If the processor is at the end of an instruction, and if the current instruction is not a RETI, and the current instruction does not involve a write to either the IP or IE registers, and the processor is not currently servicing an interrupt of equal or higher priority, then the interrupt request will be granted, and the processor will execute the interrupt service routine. Under normal operation, the program counter is incremented immediately after an opcode fetch. This action is inhibited by the interrupt, and the program counter is frozen at the current value. The interrupt service routine then pushes the program counter onto the stack, sets an internal interrupt status bit, clears the upper byte of the program counter, and loads the lower byte with the interrupt vector. Overall, the interrupt service routine behaves as a subroutine call.

Interrupt Return

The RETI instruction should be used for a return from a subroutine. This instruction is the same as a RET instruction, except that it clears the internal interrupt status bit, and thus enables future interrupts.

Power Management

The TK80C51FA provides for the two standard power management modes and for the POR status bit. The ASIC nature of the design also allows the superior method of simply stopping the clock. This method was not available in the original 8051 design due to the use of dynamic logic.

PCON (98H)		
Bit	Name	Function
7	SMOD1	Serial Port Mode 1
6	SMOD0	Serial Port Mode 0
5	-	Unused
4	POF	Power On Flag
3	GF1	General Purpose Flag 1
2	GF0	General Purpose Flag 0
1	IDLE	Idle Mode
0	PD	Power Down

SMOD1

SMOD1 is a mode control bit for the serial port.

SMOD0

SMOD0 is another mode control bit for the serial port.

Power On Flag

Bit 4 of the PCON register contains a power-on-flag. This bit is set when VDD has been applied to the part. If it is subsequently reset by software, it can be used to determine if a reset is a warm boot or a cold boot.

GF1

GF1 is a general purpose flag bit that can be used in customer applications.

GF0

GF0 is a general purpose flag bit that can be used in customer applications.

Idle Mode

The idle mode is entered by setting the IDLE bit in the PCON register. In the idle mode, the internal clock to the processor is stopped. The peripherals and the interrupt logic continue to be clocked. The processor will leave idle when either an interrupt or a reset occurs.

Power Down Mode

When the PD bit of the PCON register is set, the processor enters the power down mode. During this mode all of the clocks, including the oscillator are stopped. The only way to exit power down mode is with a reset, or with an external interrupt (INT0 or INT1).

Stopping The External Clock

The clock for the TK80C51FA may be stopped externally at any time and in any state. It may then be resumed at any time without interference with the processor operation. The only consideration is that the external clock stopping logic should not cause glitches on the clock input.

CKCON Register

Bit 0 of the CKCON register controls whether a basic instruction requires 12 clocks ($X2 = 0$) or 6 clocks ($X2 = 1$). The TK80C51FA powers up in the 12 clock mode, but may be switched to or from the 6 clock mode by software.

Data RAM Addressing

The TK80C51FA has three segments of data memory:

Lower 128 bytes of local RAM, Upper 128 bytes of local RAM, and external RAM.

The lower 128 bytes can be accessed by either direct or indirect addressing. Since the space is shared with the SFR registers, the upper 128 bytes may be accessed by indirect addressing only.

A MOVX instruction will generate an indirect access to external memory with the P3.6 (WR₋) and P3.7 (RD₋) signals at the address pointed to by the DPTR register.

Hardware Watchdog Timer

The Watch Dog Timer (WDT) is intended as method to recover from situations in which the software becomes unstable. The WDT is a 14-bit counter that is accessed through a SFR address. The WDT is disabled at reset and is enabled when the CPU writes a 1EH and E1H sequence to the WDTRST address (0A6H).

After the WDT is enabled, the CPU needs to write the same sequence as above in order to clear the timer before an overflow occurs. The 14-bit counter will overflow when the count reaches (3FFFh) and reset the device by generating a pulse on the RESET pin of 98-clock cycles width (196 in 12 clock mode).

Instruction Set

The TK80C51FA has 255 different instructions. Most are addressing variations of 35 basic instruction groups. These addressing modes provide efficient and fast data transfer between various registers, memory, and peripherals.

- Implied - The operand is implied in the opcode.
- Immediate - The operand follows the opcode.
- Register Direct - The operand is contained in a register specified in the opcode.
- Register Indirect - The operand's address is in a register specified in the opcode.
- Direct - The operand's address follows the opcode.
- Absolute - The destination address is specified in the opcode.
- Absolute Page - 11 bits of the destination address are specified in the opcode.
- Relative - The opcode specifies an offset to the present address.
- Bit Direct - The operand's bit address follows the opcode.

Many of the opcodes use bits within the opcode to identify the operand. The following abbreviations are used as "hex" characters in these cases.

```
R = 1rrr
I = 011i
Z = aaal
Y = aaa0
```

In these definitions, rrr signifies a register from R0 to R7, i signifies either R0 or R1, and aaa are address bits A10, A9, A8.

The specific implementation of an instruction is shown as:

64/3/2

which means that the machine code is 064H, there are three bytes, and it takes 2 cycles to execute.

Absolute Call

ACALL addr11

This instruction performs a subroutine call to an address within the same 2K block of memory as the first byte of the instruction immediately following the

ACALL instruction. The opcode is followed by the lower 8 bits of the subroutine address.

Z1/2/2

Add

ADD A,<Source>

This instruction adds the operand to the accumulator and stores the result in the accumulator. The C, AC, and OV flags are affected.

2R/1/1	A + Rn > A
25/2/1	A + D > A
2I/1/1	A + @Ri > A
24/2/1	A + #N > A

Add With Carry

ADDC A, <Source>

This instruction adds the operand and the carry to the accumulator, and stores the result in the accumulator. The C, AC, and OV flags are affected.

3R/1/1	A + Rn + C > A
35/2/1	A + D + C > A
3I/1/1	A + @Ri + C > A
34/2/1	A + #N + C > A

Absolute Jump

AJMP addr11

This instruction performs an absolute jump within the same 2K block as the first byte of the instruction immediately following the AJMP. The byte following the opcode contains the lower 8 address bits of the jump destination.

Y1/2/2

And

ANL <Destination>,<Source>

This instruction performs a logical AND between the source and the destination, and then stores the results in the destination.

5R/1/1	A and Rn > A
55/2/1	A and D > A
5I/1/1	A and @Ri > A
54/2/1	A and #N > A
52/2/1	D and A > D
53/3/2	D and #N > D

82/2/2 C and Bit > C
 B0/2/2 C and /Bit > C

Compare And Jump If Not Equal

CJNE <Dest.>, <Source>, <Offset>

This instruction subtracts the source from the destination, and performs a relative branch if the difference is not equal to zero. This instruction affects the carry flag.

B5/3/2 If A <> D, jump
 B4/3/2 If A <> #N, jump
 BR/3/2 If A <> Rn, jump
 BI/3/2 If A <> @Ri, jump

Clear

CLR <Source>

This instruction clears the source.

E4/1/1 0 > A
 C3/1/1 0 > C
 C2/2/1 0 > Bit

Complement

CPL <Source>

This instruction complements the source.

F4/1/1 /A > A
 B3/1/1 /C > C
 B2/2/1 /Bit > Bit

Decimal Adjust On The Accumulator

DA A

Perform a decimal adjust on the accumulator. This instruction will add 6 to the lower nibble of the accumulator if the AC flag is set or if it contains a number greater than 9. It will also add a 6 to the upper nibble if the C flag is set, or if the nibble contains a number greater than 9, or if the lower nibble contains a number greater than 9 and the upper nibble contains a 9. The Carry flag is affected.

D4/1/1 A + (66) > A

Decrement

DEC <Destination>

The decrement instruction subtracts one from the destination. No flags are affected.

14/1/1 A - 1 > A
 1R/1/1 Rn - 1 > Rn
 15/2/1 D - 1 > D
 1I/1/1 @Ri - 1 > @Ri

Divide

DIV AB

This instruction divides A by B. The quotient goes into A, and the remainder goes into B. The Carry flag is cleared. The overflow flag will be set if B contains 0. Otherwise, the overflow flag will be cleared.

84/1/4 A / B > A, B

Decrement And Jump If Not Zero

DJNZ <Source>, <Offset>

This instruction decrements the source byte. A conditional branch is made if the result is not zero. No flags are affected.

DR/2/2 Rn - 1 > Rn,
 PC + 2 > PC

 If Rn <> 0 then
 PC + Rel > PC

 D5/3/2 D - 1 > D,
 PC + 2 > PC

 If D <> 0 then
 PC + Rel > PC

Increment

INC <Source>

The increment instruction adds 1 to the source. No flags are affected.

04/1/1 A + 1 > A
 0R/1/1 Rn + 1 > Rn
 05/2/1 D + 1 > D
 0I/1/1 @Ri + 1 > @Ri
 A3/1/2 DPTR + 1 > DPTR

Conditional Branches

Jxx <Source>, <Offset>

There are seven conditional branches. If the condition is met, the offset is added to the program counter as an 8 bit signed number. No flags are affected.

40/2/2	JC, Jump if C = 1
50/2/2	JNC, Jump if C = 0
20/3/2	JB, Jump if Bit = 1
30/3/2	JNB, Jump if Bit = 0
60/2/2	JZ, Jump if A = 0
70/2/2	JNZ, Jump if A <> 0
10/3/2	JBC, Jump if Bit = 1 and clear bit

Jump Indirect

JMP @A+DPTR

This instruction adds the accumulator to the data pointer and loads the result into the program counter. No flags are affected.

73/1/2	A + DPTR > PC
--------	---------------

Long Call

LCALL addr16

This instruction performs a subroutine call to the 16 bit address. The current program counter is saved on the stack. No flags are affected.

12/3/2	Push PC on stack, New address > PC
--------	---------------------------------------

Long Jump

LJMP addr16

This instruction jumps to the 16 bit address. No flags are affected.

02/3/2	Address > PC
--------	--------------

Move

MOV <Destination>, <Source>

This instruction moves the contents of the source to the contents of the destination. No flags are affected.

ER/1/1	Rn > A
E5/2/1	D > A
EI/1/1	@Ri > A
74/2/1	#N > A
FR/1/1	A > Rn
AR/2/2	D > Rn
7R/2/1	#N > Rn
F5/2/1	A > D
8R/2/2	Rn > D
85/3/2	D > D
8I/2/2	@Ri > D
75/3/2	#N > D
FI/1/1	A > @Ri
AI/2/2	D > @Ri
7I/2/1	#N > D
A2/2/1	Bit > C
92/2/2	C > Bit
90/3/2	#N > DPTR

Move Code

MOVC <Destination>, <Source>

These instructions calculate an address in the program space and move the address contents to the accumulator. No flags are affected.

93/1/2	(A + DPTR) > A
83/1/2	(A + PC) > A

Move External Data

MOVX <Destination>, <Source>

These instructions read or write the contents of the accumulator into the data space. No flags are affected.

E0/1/2	@DPTR > A
E2/1/2	@R0 > A
E3/1/2	@R1 > A
F0/1/2	A > @DPTR
F2/1/2	A > @R0
F3/1/2	A > @R1

Multiply

MUL AB

This instruction performs an unsigned multiply between the contents of the accumulator and the B register. The sixteen bit result is stored in the B register and the Accumulator. The Carry flag is cleared. The overflow flag is set if the product is greater than 255.

A4/1/4	A * B > B, A
--------	--------------

No Operation

NOP

A NOP does nothing. The undefined opcode A5 acts as a two cycle NOP. No flags are affected.

00/1/1
A5/2/2

OR

ORL <Destination>, <Source>

This instruction does a logical OR between the source and destination..

4R/1/1 Rn or A > A
45/2/1 D or A > A
4I/1/1 @Ri or A > A
44/2/1 #N or A > A
42/2/1 D or A > D
43/3/2 #N or D > D
72/2/2 Bit or C > C
A0/2/2 /Bit or C > C

Pop Operand From Stack

POP <Destination>

This opcode moves a variable from the stack to the destination. The stack pointer is then decremented. No flags are affected.

D0/2/2 Pop D

Push Operand On Stack

PUSH <Source>

This opcode increments the stack pointer and then moves a byte from the source to the stack. No flags are affected.

C0/2/2 Push D

Return

RET

This opcode restores the program counter from the stack and decrements the stack pointer by 2. No flags are affected.

22/1/2 Stack > PC, SP-2>SP

Return From Interrupt

RETI

This opcode restores the program counter from the stack and decrements the stack pointer by 2. It also clears the interrupt status bit. No flags are affected.

32/1/2 Stack > PC, SP-2>SP

Rotate Accumulator

Rxx A

These instructions rotate the accumulator 1 bit either left or right, and either around or through the carry flag. No other flags are affected.

23/1/1 RL A - Rotate A left.
33/1/1 RLC A - Rotate A left through carry.
03/1/1 RR A - Rotate A right.
13/1/1 RRC A - Rotate A right through carry.

Set Bit

SETB <Source>

This instruction sets a specified bit. No flags are affected.

D3/1/1 1 > C
D2/2/1 1 > Bit

Short Jump

SJMP <Offset>

This opcode is an unconditional branch. The offset is treated as a signed 8 bit number that is added to the program counter. No flags are affected.

80/2/2 PC + Offset > PC

Subtract With Borrow

SUBB <Destination>, <Source>

This opcode subtracts the source and the carry from the accumulator, and stores the results in the accumulator. The C, AC and OV flags are affected.

9R/1/1 A - C - Rn > A
95/2/1 A - C - D > A

```

9I/1/1      A - C - @Ri > A
94/2/1      A - C - #N > A
    
```

Swap Nibbles In Accumulator

SWAP A

This instruction swaps the nibbles in the accumulator. No flags are affected.

```

C4/1/1      A(0-3) <-> A(4-7)
    
```

Exchange Accumulator With Operand

XCH A, <Source>

This instruction exchanges the accumulator with operand. No flags are affected.

```

CR/1/1      A <-> Rn
C5/2/1      A <-> D
CI/1/1      A <-> @Ri
    
```

Exchange Digit Within Accumulator With Operand

XCHD A, <Source>

This instruction exchanges a nibble between the accumulator and the operand. No flags are affected.

```

DI/1/1      A(0-3) <-> @Ri(0-3)
    
```

Exclusive Or

XRL <Destination>, <Source>

This instruction performs an exclusive-or between the source and destination. No flags are affected.

```

6R/1/1      A xor Rn > A
65/2/1      A xor D > A
6I/1/1      A xor @Ri > A
64/2/1      A xor #N > A
62/2/1      D xor A > D
63/3/2      D xor #N > D
    
```

Op-Code Map

		Lower 4 Bits																
		0	1	2	3	4	5	6	7	8	9	A	B	C	D	E	F	
Upper 4 Bits	0	NOP	AJMP	LJMP	RR A	INC A	INC D	INC @R0	INC @R1	INC R0	INC R1	INC R2	INC R3	INC R4	INC R5	INC R6	INC R7	0
	1	JBC	ACALL	LCALL	RRC A	DEC A	DEC D	DEC @R0	DEC @R1	DEC R0	DEC R1	DEC R2	DEC R3	DEC R4	DEC R5	DEC R6	DEC R7	1
	2	JB	AJMP	RET	RL A	ADD A, N	ADD A, D	ADD @R0	ADD @R1	ADD A, R0	ADD A, R1	ADD A, R2	ADD A, R3	ADD A, R4	ADD A, R5	ADD A, R6	ADD A, R7	2
	3	JNB	ACALL	RETI	RLC A	ADDC A, N	ADDC A, D	ADDC @R0	ADDC @R1	ADDC A, R0	ADDC A, R1	ADDC A, R2	ADDC A, R3	ADDC A, R4	ADDC A, R5	ADDC A, R6	ADDC A, R7	3
	4	JC	AJMP	OR D, A	ORL D, #N	ORL A, N	ORL A, D	ORL @R0	ORL @R1	ORL A, R0	ORL A, R1	ORL A, R2	ORL A, R3	ORL A, R4	ORL A, R5	ORL A, R6	ORL A, R7	4
	5	JNC	ACALL	ANL D, A	ANL D, #N	ANL A, N	ANL A, D	ANL @R0	ANL @R1	ANL A, R0	ANL A, R1	ANL A, R2	ANL A, R3	ANL A, R4	ANL A, R5	ANL A, R6	ANL A, R7	5
	6	JZ	AJMP	XRL D, A	XRL D, #N	XRL A, N	XRL A, D	XRL @R0	XRL @R1	XRL A, R0	XRL A, R1	XRL A, R2	XRL A, R3	XRL A, R4	XRL A, R5	XRL A, R6	XRL A, R7	6
	7	JNZ	ACALL	OR C, Bit	JMP @A+DP	MOV A, N	MOV D, N	MOV @R0, N	MOV @R1, N	MOV R0, N	MOV R1, N	MOV R2, N	MOV R3, N	MOV R4, N	MOV R5, N	MOV R6, N	MOV R7, N	7
	8	SJMP	AJMP	ANL C, Bit	MOVC A+PC	DIV A, B	MOV D, D	MOV D, @R0	MOV D, @R1	MOV R0, D	MOV R1, D	MOV R2, D	MOV R3, D	MOV R4, D	MOV R5, D	MOV R6, D	MOV R7, D	8
	9	MOV DP, N	ACALL	MOV Bit, C	MOVC A+DP	SUBB A, N	SUBB A, D	SUBB @R0	SUBB @R1	SUBB A, R0	SUBB A, R1	SUBB A, R2	SUBB A, R3	SUBB A, R4	SUBB A, R5	SUBB A, R6	SUBB A, R7	9
	A	OR C, /Bit	AJMP	MOV C, Bit	INC DP	MUL A, B	NOP	MOV @R0, D	MOV @R1, D	MOV R0, D	MOV R1, D	MOV R2, D	MOV R3, D	MOV R4, D	MOV R5, D	MOV R6, D	MOV R7, D	A
	B	ANL C, /Bit	ACALL	CPL BIT	CPL C	CJNE A, N	CJNE A, D	CJNE @R0	CJNE @R1	CJNE R0, N	CJNE R1, N	CJNE R2, N	CJNE R3, N	CJNE R4, N	CJNE R5, N	CJNE R6, N	CJNE R7, N	B
	C	PUSH	AJMP	CLR Bit	CLR C	SWAP A	XCH A, D	XCH @R0	XCH @R1	XCH A, R0	XCH A, R1	XCH A, R2	XCH A, R3	XCH A, R4	XCH A, R5	XCH A, R6	XCH A, R7	C
	D	POP	ACALL	SETB D	SETB C	DAA	DJNZ D	XCHD @R0	XCHD @R1	DJNZ R0	DJNZ R1	DJNZ R2	DJNZ R3	DJNZ R4	DJNZ R5	DJNZ R6	DJNZ R7	D
	E	MOVX A, @DP	AJMP	MOVX A, @R0	MOVX A, @R1	CLR A	MOV A, D	MOV A, @R0	MOV A, @R1	MOV A, R0	MOV A, R1	MOV A, R2	MOV A, R3	MOV A, R4	MOV A, R5	MOV A, R6	MOV A, R7	E
	F	MOVX @DPA	ACALL	MOVX @R0, A	MOVX @R1, A	CPL A	MOV D, A	MOV @R0, A	MOV @R1, A	MOV R0, A	MOV R1, A	MOV R2, A	MOV R3, A	MOV R4, A	MOV R5, A	MOV R6, A	MOV R7, A	F
		0	1	2	3	4	5	6	7	8	9	A	B	C	D	E	F	

Electrical Specifications

Maximum Ratings

Characteristics		Symbol	Min	Max	Unit
Supply Voltage		V _{dd}	-0.5	5.5	V
Input Voltage		V _{in}	V _{ss} - 0.3	V _{dd} + 0.3	V
Current Drain per Pin		I _{OL}		15	mA
Operating Temperature Range	Commercial	T _{ac}	0	70	°C
	Industrial	T _{ai}	-40	85	°C
Storage Temperature range		T _{stg}	-55	+150	°C

DC Electrical Specifications (V_{dd} = 5.0 V +/- 10%, V_{ss} = 0 V, T_a = 0°C to +70°C)

Characteristics	Condition	Symbol	Min	Max	Unit
Input high level (Ports 0, 1, 2, 3, /EA)		V _{IH}	2.0	V _{dd}	V
Input high level (X1, RST)		V _{IH1}	2.0	V _{dd}	V
Input low level		V _{IL}	0.0	0.8	V
Output high level	I _{oh} = 2 mA	V _{OH}	2.4	V _{dd}	V
Output high level	I _{oh} = 4 mA	V _{OH1}	2.4	V _{dd}	V
Output low level	I _{ol} = 2 mA	V _{OL}	0	0.4	V
Output low level	I _{ol} = 4 mA	V _{OL1}	0	0.4	V
Input current (Ports 1, 2, 3)	V _{IN} = 0.4 V	I _{LI}	-10	10	uA
Logical 1 to 0 transition current (Ports 1, 2, 3)	I _{tl}	I _L	-10	10	uA
Input Leakage current (Port 0)		I _L	-10	10	uA
Supply current, Active mode,	X1 = 12 MHz	I _{CCA}		20	mA
Internal Reset Pull-Down Resistor	V _{in} = 0V	R _{RST}	-10	10	uA
Pin Capacitance	C _{io}	C _{IO}		10	uA

Notes:

1. AC measurements made with a 50 pF load, at a 50% supply voltage level.
2. Float delay measured with a 3.3K resistor tied to opposite supply, measured after a +/- 0.2V change in voltage level.

AC Electrical Specifications (V_{dd} = 3.3 V +/- 10%, V_{ss} = 0 V, T_a = 0°C to +70°C)

Characteristics	Symbol	Min	Max	Unit
Oscillator frequency	1/t _{clcl}	0	33	MHz
ALE pulse width	t _{lhll}	2t _{clcl} -40		ns
Address valid to ALE low	t _{avll}	t _{clcl} -25		ns
Address Hold after ALE low	t _{llax}	t _{clcl} -25		ns
ALE low to valid instruction in	t _{lliv}		4t _{clcl} -65	ns
ALE low to PSEN low	t _{llpl}	t _{clcl} -25		ns
PSEN pulse width	t _{plph}	3t _{clcl} -45		ns
PSEN low to valid instruction in	t _{pliv}		3t _{clcl} -60	ns
Input instruction hold after PSEN	t _{pxix}	0		ns
Input instruction float after PSEN	t _{pxiz}		t _{clcl} -25	ns
Address to valid instruction in	t _{aviv}		5t _{clcl} -80	ns
PSEN low to address float	t _{plaz}		10	ns
Data Memory				
RD pulse width	t _{rlrh}	6t _{clcl} -100		ns
WR pulse width	t _{wlwh}	6t _{clcl} -100		ns
RD low to valid data in	t _{rldv}		5t _{clcl} -90	ns
Data hold after RD	t _{rhdx}	0		ns
Data float after RD	t _{rhdz}		2t _{clcl} -28	ns
ALE low to data valid	t _{lldv}		8t _{clcl} -150	ns
Address to valid data in	t _{avdv}		9t _{clcl} -165	ns
ALE low to RD or WR low	t _{llwl}	3t _{clcl} -50	3t _{clcl} -50	ns
Address valid to WR low or RD low	t _{avwl}	4t _{clcl} -75		ns
Data Valid to WR transition	t _{qvwx}	t _{clcl} -30		ns
Data hold after WR	t _{whqx}	t _{clcl} -25		ns
Data valid to WR high	t _{qvwh}	7t _{clcl} -130		ns
RD low to address float	t _{rlaz}			ns
RD or WR high to ALE high	t _{whlh}	t _{clcl} -25		ns

Notes:

3. AC measurements made with a 50 pF load, at a 50% supply voltage level.
4. Float delay measured with a 3.3K resistor tied to opposite supply, measured after a +/- 0.2V change in voltage level.

Timing Diagrams

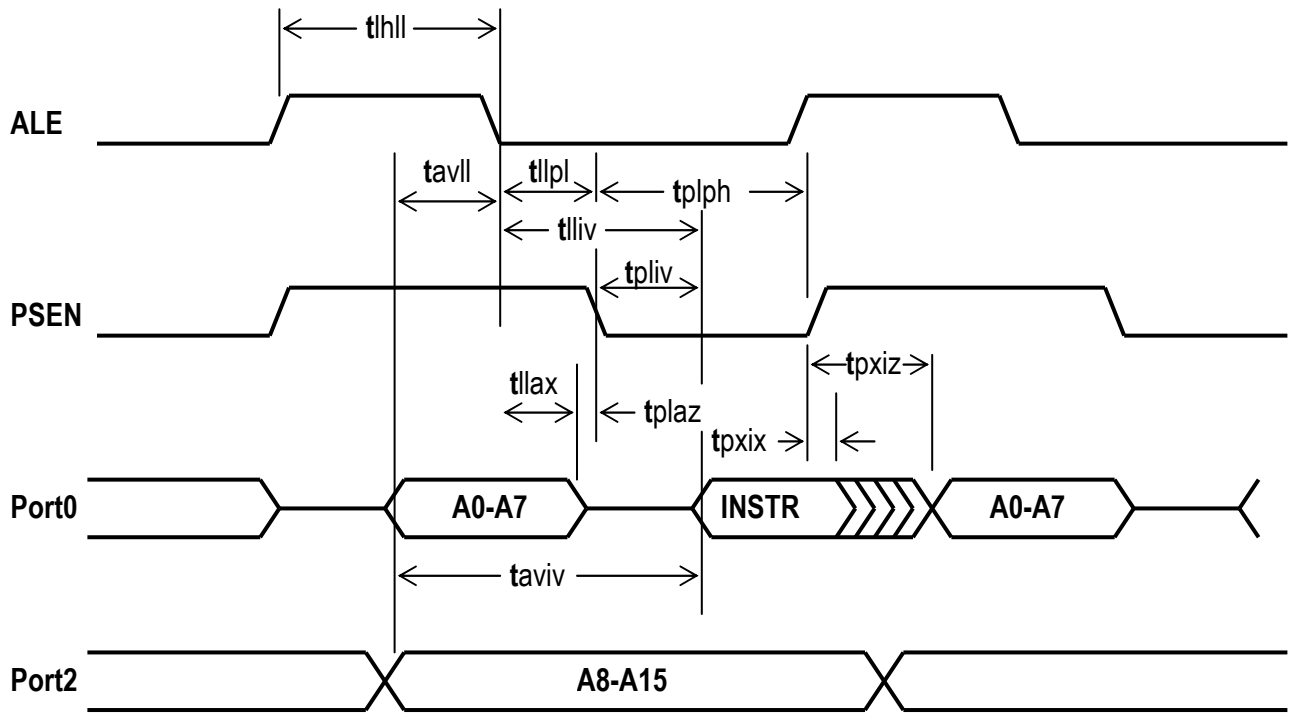

Figure Time-1 – External Program Memory Read Cycle

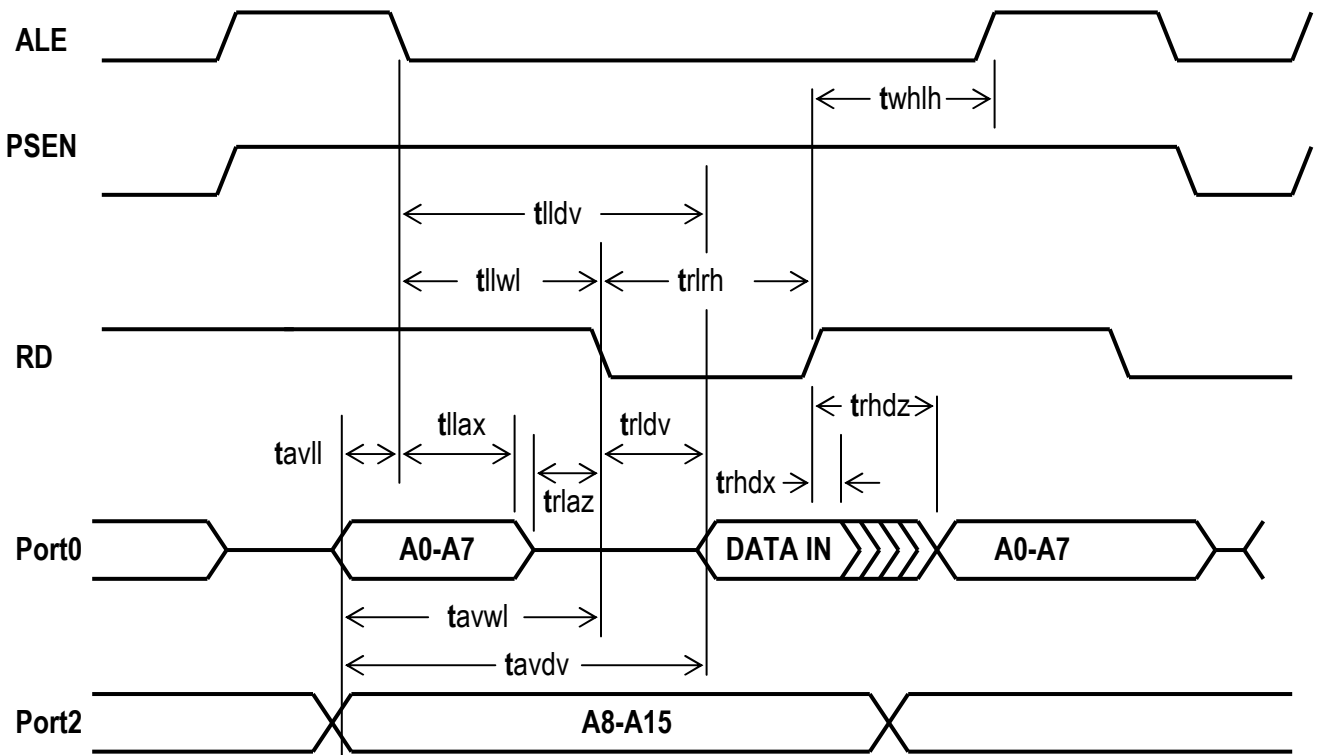

Figure Time-2 – External Program Memory Read Cycle

Differences Between Tekmos and Older Parts

In general, the TK80C51FA is a superset of older parts. Code that does not reference undefined registers or memory should work correctly in the Tekmos part. This table summarizes the main functional differences between the different generations of 8051 devices.

Feature	Tekmos	80C31 BH	80C32 -1	80C51FA	80C32X2
RAM (Bytes)	256	128	256	256	256
Interrupts	7	5	6	7	6
Interrupt Priority Levels	4	2	2	4	4
Data Pointers	2	1	1	1 or 2	2
UART – Basic	Yes	Yes	Yes	Yes	Yes
UART - Enhanced	Yes	No	No	Yes	Yes
Timer 0 & 1	Yes	Yes	Yes	Yes	Yes
Timer 2 – Basic	Yes	No	Yes	Yes	Yes
Timer 2 - Enhanced	Yes	No	No	Yes	Yes
PCA	Yes	No	No	Yes	No
POF (Power Off Flag)	Yes	No	No	Yes	Yes
X2 Clock Control	Yes	No	No	No	Yes
Hardware Watchdog	Yes	No	No	No	No

Industry Cross References

The TK80C51FA contains a superset of previous 8051 architectures. As a result, it may be used to replace many earlier devices. The following table provides a cross reference.

Cross Reference for Intel Devices

Device	Temp	Speed	Package	Tekmos Replacement	Note
80C31BH Family					
BE80C31BH-1	M	16	PDIP	TK80C51FA-PM	1
EE80C31BH-1	C	16	PDIP	TK80C51FA-PC	
EN80C31BH-1	C	16	PLCC	TK80C51FA-AC	
ES80C31BH-1	C	16	LQFP	TK80C51FA-BC	
LD80C31BH-1	I	16	CERDIP	TK80C51FA-PI	1, 2
LN80C31BH-1	I	16	PLCC	TK80C51FA-AI	1
LP80C31BH-1	I	16	PDIP	TK80C51FA-PI	1
N80C31BH-1	C	16	PLCC	TK80C51FA-AC	
P80C31BH-1	C	16	PDIP	TK80C51FA-PC	
S80C31BH-1	C	16	LQFP	TK80C51FA-BC	
TN80C31BH-1	I	16	PLCC	TK80C51FA-AI	
TP80C31BH-1	I	16	PDIP	TK80C51FA-PI	
UJ80C31BH-1					3
80C32 Family					
P80C32-1	C	16	PDIP	TK80C51FA-PC	
P80C32-24	C	24	PDIP	TK80C51FA-PC	
N80C32-1	C	16	PLCC	TK80C51FA-AC	
N80C32-24	C	24	PLCC	TK80C51FA-AC	
TP80C32-1	I	16	PDIP	TK80C51FA-PI	
TN80C32-1	I	16	PLCC	TK80C51FA-AI	
LP80C32-1	I	16	PDIP	TK80C51FA-PI	1
LN80C32-1	I	16	PLCC	TK80C51FA-AI	1
80C51 Family					
P80C51FA-1	C	16	PDIP	TK80C51FA-PC	
P80C51FA-24	C	24	PDIP	TK80C51FA-PC	
N80C51FA-1	C	16	PLCC	TK80C51FA-AC	
N80C51FA-24	C	24	PLCC	TK80C51FA-AC	
TP80C51FA-1	I	16	PDIP	TK80C51FA-PI	
TN80C51FA-1	I	16	PLCC	TK80C51FA-AI	
LP80C51FA-1	I	16	PDIP	TK80C51FA-PI	1
LN80C51FA-1	I	16	PLCC	TK80C51FA-AI	1

Notes:

1. Tekmos part is not burned-in. Burn-in services are available. Contact Factory
2. PDIP package replacing CERDIP package.
3. Contact Factory for specification matching.
4. Tekmos parts have a maximum speed of 20 MHz with 6X clock
- 5.

Cross Reference for NXP Devices

Device	Temp	Speed	Package	Tekmos Replacement	Note
80C31 Family					
P80C31SBAA	C	16	PLCC	TK80C51FA-AC	
P80C31SBBB	C	16	LQFP	TK80C51FA-BC	
P80C31SBPN	C	16	PDIP	TK80C51FA-PC	
P80C31SFAA	I	16	PLCC	TK80C51FA-AI	
P80C31SFBB	I	16	LQFP	TK80C51FA-BI	
P80C31SFPN	I	16	PDIP	TK80C51FA-PI	
P80C31UBAA	C	33	PLCC	TK80C51FA-AC	
P80C31UBBB	C	33	LQFP	TK80C51FA-BC	
P80C31UBPN	C	33	PDIP	TK80C51FA-PC	
P80C31UFAA	I	33	PLCC	TK80C51FA-AI	
P80C31UFBB	I	33	LQFP	TK80C51FA-BI	
P80C31UFPN	I	33	PDIP	TK80C51FA-PI	
80C32 Family					
P80C32EBPN			PLCC	TK80C51FA-PC	1
P80C32IBAA	C	33	PLCC	TK80C51FA-AC	
P80C32IBBB	C	33	LQFP	TK80C51FA-BC	
P80C32IBPN	C	33	PDIP	TK80C51FA-PC	
P80C32NBPN			PDIP	TK80C51FA-PC	1
P80C32SBAA	C	16	PLCC	TK80C51FA-AC	
P80C32SBBB	C	16	LQFP	TK80C51FA-BC	
P80C32SBPN	C	16	PDIP	TK80C51FA-PC	
P80C32SFAA	I	16	PLCC	TK80C51FA-AI	
P80C32SFBB	I	16	LQFP	TK80C51FA-BI	
P80C32SFPN	I	16	PDIP	TK80C51FA-PI	
P80C32UBAA	C	33	PLCC	TK80C51FA-AC	
P80C32UBBB	C	33	LQFP	TK80C51FA-BC	
P80C32UBPN	C	33	PDIP	TK80C51FA-PC	
P80C32UFAA	I	33	PLCC	TK80C51FA-AI	
P80C32UFBB	I	33	LQFP	TK80C51FA-BI	
P80C32UFPN	I	33	PDIP	TK80C51FA-PI	
80C32X2 Family					
P80C31X2BA	C	30/33	PLCC	TK80C51FA-AC	2
P80C31X2BN	C	30/33	PDIP	TK80C51FA-PC	2
P80C32X2BA	C	30/33	PLCC	TK80C51FA-AC	2
P80C32X2BN	C	30/33	PDIP	TK80C51FA-PC	2
P80C32X2BBD	C	30/33	LQFP	TK80C51FA-BC	2
P80C32X2FA	I	30/33	PLCC	TK80C51FA-AI	2
P80C32X2FN	I	30/33	PDIP	TK80C51FA-PI	2
P80C32X2FBD	I	30/33	LQFP	TK80C51FA-BI	2

Cross Reference for NXP Devices (Continued)

Device	Temp	Speed	Package	Tekmos Replacement	Note
80C51FA Family					
P80C51FA-4N	C	16	PDIP	TK80C51FA-PC	
P80C51FA-4A	C	16	PLCC4	TK80C51FA-AC	
P80C51FA-4B	C	16	PQFP	TK80C51FA-BC	
P80C51FA-5N	I	16	PDIP	TK80C51FA-PI	
P80C51FA-5A	I	16	PLCC	TK80C51FA-AI	
P80C51FA-5B	I	16	PQFP	TK80C51FA-BI	
P80C51FA-IN	C	33	PDIP	TK80C51FA-PC	
P80C51FA-IA	C	33	PLCC	TK80C51FA-AC	
P80C51FA-IB	C	33	PQFP	TK80C51FA-BC	
P80C51FA-JN	I	33	PDIP	TK80C51FA-PI	
P80C51FA-JA	I	33	PLCC	TK80C51FA-AI	
P80C51FA-JB	I	33	PQFP	TK80C51FA-BI	

Notes:

1. Check with factory for specification matching.
2. Tekmos parts have a maximum speed of 20 MHz with 6X clock

Cross Reference for Atmel Devices (Continued)

Device	Temp	Speed	Package	Tekmos Replacement	Note
80C32X2 Family					
TS80C32X2-MCA	C	40	PDIP	TK80C51FA-PC	
TS80C32X2-MCB	C	40	PLCC	TK80C51FA-AC	
TS80C32X2-MCC	C	40	LQFP	TK80C51FA-BC	
TS80C32X2-MCE	C	40	TQFP	TK80C51FA-CC	
TS80C32X2-LCA	C	30	PDIP	TK80C51FA-PC	
TS80C32X2-LCB	C	30	PLCC	TK80C51FA-AC	
TS80C32X2-LCC	C	30	LQFP	TK80C51FA-BC	
TS80C32X2-LCE	C	30	TQFP	TK80C51FA-CC	
TS80C32X2-VCA	C	60	PDIP	TK80C51FA-PC	1
TS80C32X2-VCB	C	60	PLCC	TK80C51FA-AC	1
TS80C32X2-VCC	C	60	LQFP	TK80C51FA-BC	1
TS80C32X2-VCE	C	60	TQFP	TK80C51FA-CC	1
TS80C32X2-MIA	I	40	PDIP	TK80C51FA-PI	
TS80C32X2-MIB	I	40	PLCC	TK80C51FA-AI	
TS80C32X2-MIC	I	40	LQFP	TK80C51FA-BI	
TS80C32X2-MIE	I	40	TQFP	TK80C51FA-CI	
TS80C32X2-LIA	I	30	PDIP	TK80C51FA-PI	
TS80C32X2-LIB	I	30	PLCC	TK80C51FA-AI	
TS80C32X2-LIC	I	30	LQFP	TK80C51FA-BI	
TS80C32X2-LIE	I	30	TQFP	TK80C51FA-CI	
TS80C32X2-VIA	I	60	PDIP	TK80C51FA-PI	1
TS80C32X2-VIB	I	60	PLCC	TK80C51FA-AI	1
TS80C32X2-VIC	I	60	LQFP	TK80C51FA-BI	1
TS80C32X2-VIE	I	60	TQFP	TK80C51FA-CI	1
AT80C32X2-3CSUM	I	40	PDIP	TK80C51FA-PI	
AT80C32X2-SLSUM	I	40	PLCC	TK80C51FA-AI	
AT80C32X2-RLTUM	I	40	TQFP	TK80C51FA-CI	
AT80C32X2-3CSUL	I	30	PDIP	TK80C51FA-PI	
AT80C32X2-SLSUL	I	30	PLCC	TK80C51FA-AI	
AT80C32X2-RLTUL	I	30	TQFP	TK80C51FA-CI	
AT80C32X2-3CSUV	I	60	PDIP	TK80C51FA-PI	1
AT80C32X2-SLSUV	I	60	PLCC	TK80C51FA-AI	1
AT80C32X2-RLTUV	I	60	TQFP	TK80C51FA-CI	1
AT80C32X2-DDV	I	60	Die	TK80C51FA-DI	1, 2
AT80C32X2-RLFUM	I	40	TQFP	TK80C51FA-CI	
AT80C32X2-RLRUL	I	30	TQFP	TK80C51FA-CI	
AT80C32X2-RLRUL	I	30	TQFP	TK80C51FA-CI	
AT80C32X2-RLRUM	I	40	TQFP	TK80C51FA-CI	
AT80C32X2-RLRUV	I	60	TQFP	TK80C51FA-CI	1
AT80C32X2-RLTXL	M	30	TQFP	TK80C51FA-CI	3
AT80C32X2-RLVUM	I	40	TQFP	TK80C51FA-CI	
AT80C32X2-SLRUL	I	30	PLCC	TK80C51FA-AI	
AT80C32X2-SLRUM	I	40	PLCC	TK80C51FA-AI	
AT80C32X2-SLRUV	I	60	PLCC	TK80C51FA-AI	1
AT80C32X2-SLTUM	I	40	PLCC	TK80C51FA-AI	

Cross Reference for Atmel Devices

Device	Temp	Speed	Package	Tekmos Replacement	Note
80C31X2 Family					
TS80C31X2-MCA	C	40	PDIP	TK80C51FA-PC	
TS80C31X2-MCB	C	40	PLCC	TK80C51FA-AC	
TS80C31X2-MCC	C	40	LQFP	TK80C51FA-BC	
TS80C31X2-MCE	C	40	TQFP	TK80C51FA-CC	
TS80C31X2-LCA	C	30	PDIP	TK80C51FA-PC	
TS80C31X2-LCB	C	30	PLCC	TK80C51FA-AC	
TS80C31X2-LCC	C	30	LQFP	TK80C51FA-BC	
TS80C31X2-LCE	C	30	TQFP	TK80C51FA-CC	
TS80C31X2-VCA	C	60	PDIP	TK80C51FA-PC	1
TS80C31X2-VCB	C	60	PLCC	TK80C51FA-AC	1
TS80C31X2-VCC	C	60	LQFP	TK80C51FA-BC	1
TS80C31X2-VCE	C	60	TQFP	TK80C51FA-CC	1
TS80C31X2-MIA	I	40	PDIP	TK80C51FA-PI	
TS80C31X2-MIB	I	40	PLCC	TK80C51FA-AI	
TS80C31X2-MIC	I	40	LQFP	TK80C51FA-BI	
TS80C31X2-MIE	I	40	TQFP	TK80C51FA-CI	
TS80C31X2-LIA	I	30	PDIP	TK80C51FA-PI	
TS80C31X2-LIB	I	30	PLCC	TK80C51FA-AI	
TS80C31X2-LIC	I	30	LQFP	TK80C51FA-BI	
TS80C31X2-LIE	I	30	TQFP	TK80C51FA-CI	
TS80C31X2-VIA	I	60	PDIP	TK80C51FA-PI	1
TS80C31X2-VIB	I	60	PLCC	TK80C51FA-AI	1
TS80C31X2-VIC	I	60	LQFP	TK80C51FA-BI	1
TS80C31X2-VIE	I	60	TQFP	TK80C51FA-CI	1
AT80C31X2-3CSUM	I	40	PDIP	TK80C51FA-PI	
AT80C31X2-SLSUM	I	40	PLCC	TK80C51FA-AI	
AT80C31X2-RLTUM	I	40	TQFP	TK80C51FA-CI	
AT80C31X2-3CSUL	I	30	PDIP	TK80C51FA-PI	
AT80C31X2-SLSUL	I	30	PLCC	TK80C51FA-AI	
AT80C31X2-RLTUL	I	30	TQFP	TK80C51FA-CI	

Notes

1. Tekmos parts have a maximum speed of 40 MHz.
2. Tekmos die is different size and with different bond pads and pad locations than Atmel die. Please contact factory for details.
3. Check with factory for suitability

Ordering Information

Here is the explanation for the TK80C51FA ordering codes.

Device	Temperature Specification	Package
TK80C51FA-PC	0 C – 70 C	PDIP 40
TK80C51FA-PI	-40 C – 85 C	PDIP 40
TK80C51FA-AC	0 C – 70 C	PLCC 44
TK80C51FA-AI	-40 C – 85 C	PLCC 44
TK80C51FA-BC	0 C – 70 C	LQFP 44
TK80C51FA-BI	-40 C – 85 C	LQFP 44
TK80C51FA-CC	0 C – 70 C	TQFP 44
TK80C51FA-CI	-40 C – 85 C	TQFP 44
TK80C51FA-DI	-40 C – 85 C	Die in Wafer Form

Contact Information

The TK80C51FA series may be ordered directly from Tekmos

Tekmos, Inc.
 4120 Commercial Center Drive
 Suite 400
 Austin, TX 78744

512 342-9871 phone
 512 342-9873 fax
 Sales@Tekmos.Com
 www.Tekmos.com

Revision History

Date	Revision	Description
1/19/09	1.0	Initial Release
2/9/09	1.1	Add part number cross reference table

© 2009 Tekmos, Inc.

Information contained in this publication regarding device applications and the like is intended for suggestion only and may be superseded by updates. No representation or warranty is given and no liability is assumed by Tekmos Incorporated with respect to the accuracy or use of such information, or infringement of patents or other intellectual property rights arising from such use or otherwise. Use of Tekmos' products as critical components in life support systems is not authorized except with express written approval by Tekmos. No licenses are conveyed, implicitly or otherwise, under any intellectual property rights. The Tekmos logo and name are registered trademarks of Tekmos, Inc. All rights reserved. All other trademarks mentioned herein are the property of their respective companies. All rights reserved.

Terms and product names in this document may be trademarks of others.